



Location

Studio



Last updated on November 2022

User manual





Introduction

About this guide

This guide provides information about how to use the product functions to illuminate with this equipment as well as warnings on his use.

These are products of professional use for exterior and interior locations or studio and must be operated only by qualified technical personnel.

To obtain the maximum features, please read the following operating instructions very carefully before using this fixture for the first time. Please keep these operating instructions for you and subsequent users to reference in the future.

THELIGHT Luminary for cine and TV, S.L.

Safety precautions

For your own safety, please read and follow all safety instructions and warnings.

Exemption from liability

VELVET (THELIGHT Luminary) does not assume any responsibility for lighting failures caused by malfunction of this product. The manufacturer disclaims liability for any damage to persons or property caused by inappropriate operation, damage of this kind lies in the responsibility of the operator.

Warranty

This product is manufactured to local specifications and the warranty is valid within the country of purchase. Should the product fail or malfunction while you are abroad, the manufacturer assumes no responsibility for servicing the product locally or bearing the expenditure incurred thereof.

The total or partial reproduction of this guide is prohibited without the express written permission of VELVET.

VELVET technology is protected under Spanish license laws with international patents pending. Information and specifications in this document are subject to change without notice.

2022 © Copyright VELVET. All rights reserved.
www.velvetlight.tv

Working conditions

- Maximum allowed tilt angles are 90° up and 90° down.
- Ambient temperature (at the place of operation or storage):
Minimum -20°C Maximum + 45°C
- Minimum distances from inflammable surface:

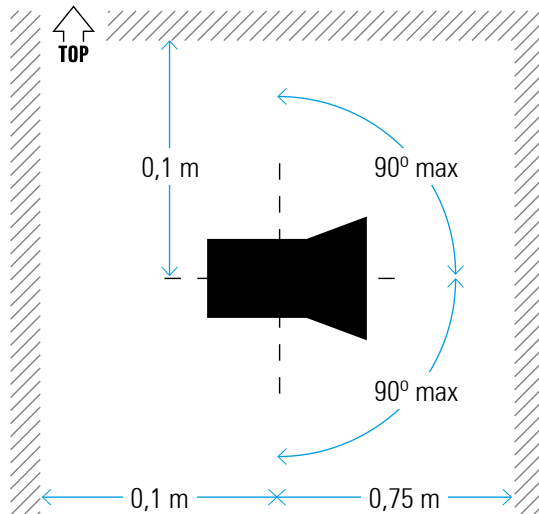

Safety precautions

Various symbols are used throughout this instruction manual and on the product to prevent physical harm to you or other people and damage to property. The symbols and their meanings are explained below.



This symbol indicates the risk of electric shock or fire danger that could result in injury or damage to equipment.

In order to protect against risk of electric shock, the installation should be properly grounded. Defeating the purpose of the grounding type plug will expose you to the risk of electric shock.

Disconnect the KOSMOS from the mains voltage before replacing a damaged fuse. Never bridge a fuse.



Possible risk of injury or damage to equipment.

Fire risk

The housing can reach high temperatures. Keep a safety distance of 0,25 m / 10" to adjacent surfaces on all sides of the fixture.

Do not cover the lamp head while using it. Proper ventilation must be provided on the upper ventilation slots and the bottom air filter.

Avoid exposing the lamp head to the heat radiation of other light fixtures.

Do not place the product on heat sources.

Do not power on the product if the ambient temperature exceeds 45° C.

Keep the cables away from the fixture.

High light beam intensity

The lamp head is equipped with power LED. Due to their high light-output intensity don't stare directly into the light source.

Do not open the product. Doing so will invalidate the product warranty.

Do not attempt to repair any part of the product on your own.

Maintenance and repair work to be carried out only by VELVET Service Centre.

Never connect the product to a dimmer system or a dimmer channel in non-dim mode. Doing so will damage the KOSMOS fixture electronics. Damages caused by connecting the product to a not suitable power source are not covered by the warranty.

Never point a light beam from another fixture into the light KOSMOS source.



Though the light generated by LED does not produce any heat, for what his use turns out to be very comfortable for the actors, the lamp head acts as a heat sink through its back part. Surface can reach a temperature between the 20°C and the 60°C. Please use protective gloves if you touch the lamp head at the heat sink.



This equipment has been checked and meets the requirements of general safety for electronic devices. These requirements are specified to provide a reasonable protection against electromagnetic interferences when the equipment is used in commercial environments.

This equipment generates, uses and can emit waves of radio frequency, and if not properly used following the instructions of this manual can produce interferences in radio communications. The use of this equipment in residential areas can produce interference, the user will be the only responsible of correcting them.

Table of contents

A	Main features	09
	Firmware updates history	12
B	KOSMOS range models	13
C	KOSMOS 400 Location	
	Parts	14
	Specifications	15
	Photometrics	16
	Power options	17
D	KOSMOS 400 Location accessories	
	Light Engine	19
	Rigging	19
	Battery adapters	19
	Beam Control	20
	Transport	20
	Remote Control	21
	Cables	21
E	KOSMOS 400 Studio	
	Parts	22
	Specifications	23
	Photometrics	24
	Power options	25
F	KOSMOS 400 Studio accessories	
	Light Engine	26
	Rigging	26
	Beam Control	26
	Remote Control	27
	Cables	27
G	Placing into operation	
	Yoke to fixture assembling	28
	Pole Operate to fixture assembling	32
	Mounting and security	34
H	Accessories installation	
	Barndors installation	35
	Snapbag, Snapgrid and Lantern installation	36

I	Diagrams	
	KOSMOS Location / Studio	37
J	Menu overview	
	Power on/off	38
	Display overview	38
	Display structure	39
	Control options	41
K	Zoom and Control Modes	
	Zoom / Beam angle adjustment	42
	CCT Mode / White light	42
	HSI Mode	43
	RGB Mode	44
	GEL Mode	45
	GEL Mode / Lists sorting	46
	"L" Gels list	47
	"R" Gels list	50
	Presets	52
	Effects	53
	Effects list	55
L	Settings	
	DMX-RDM control	57
	8 bits DMX map chart	59
	16 bits DMX map chart	68
	Kelvin DMX	78
	Dimming curve	79
M	Fixture control	
	Ethernet	80
	Wireless control	81
	Wi-fi Art Net	82
	Bluetooth	85
	Velvet Goya App	88
	About	91
	Firmware update	91
	Maintenance and care	92
N	Regulations	94
O	Warranty	96
P	QR links	98

Main features

Welcome

Thank you for selecting KOSMOS LED Fresnel from VELVET. The KOSMOS are compact color-tunable Fresnel producing unprecedented output with motorized ZOOM and total wireless control. KOSMOS are much more efficient than a traditional tungsten Fresnel and are the LED color-tunable Fresnel efficiency market leaders.

The KOSMOS emit variable color light with adjustable color temperature, adjustable green/magenta correction and remotely controlled beam angle. Every KOSMOS model can be controlled using DMX-RDM protocol, Art-Net through LumenRadio wireless, Wi-fi Art-Net, Bluetooth or locally with full-color touchscreen plus two rotary knobs.

Control advantages

- You can locally or remotely adjust the beam angle with any control mode.
 - Any base white light color temperature between 2500 and 9900K can be set to apply over any color or gel.
-

Electronic zoom

With KOSMOS you are entering on the digital beam control era. From 13° spot to 56° flood, digital beam control allows you to change the beam angle, mid-shot without manual adjustment. No hassle replacing fixed optics to have different beam angles.

With KOSMOS beam change is instant at your fingertips, local or remotely, with a DMX wire or wireless.

V5 ceramic light engine

VELVET KOSMOS includes a state of the art VELVET proprietary super compact 35mm full-color light engine. A total of 212 Red, Green, Blue, Warm White and Cool White high-power LED are arranged over a ceramic substrate with a special distribution to produce a homogeneous beam of very powerful light.

The light engine compact diameter acts as a point source to produce sharp, single shadow light with bright and saturated colors. The finest quality Red, Green and Blue LED emit highly saturated colors while the addition of high CRI Warm and Cool white LED produce a massive amount of white light over only color light engines.

The KOSMOS V5LED technology (R+G+B+W+CW) offers clear advantages on light quality and color adjustment:

- More saturated colors
- More natural white light with much wider color gamut
- Higher degree of color control
- Higher light output and less electric consumption thanks to its ceramic light engine efficiency

3D chamber cooling system

Compactness comes from an extremely compact and lightweight cooling system designed by VELVET.

Every KOSMOS includes a passive liquid cooling system contained into a sealed 3D copper chamber with a silent fan protected by an air filter.

This advanced cooling system is controlled with three heat sensors and a variable speed silent fan to keep not only the light engine but also the electronics at the optimum temperature.

Glass fresnel lens

A true 12" (300 mm) borosilicate glass Fresnel lens produces a traditional effect, consistently creating 13° to 56° single-shadow beam angles, clean color reproduction and ensuring years of reliable operation.

The big size of the lens produce a natural, hard and directional Fresnel light with the VELVET character to create real image

Total control built-in

KOSMOS can be fully, quickly and easily controlled in any possible way, locally or wirelessly, or from your smartphone with VELVET App

Wireless control

DMX-RDM through LumenRadio CRMX (only KOSMOS Location version)

Wi-Fi Art-Net to control from Smartphone or tablet with VELVET Goya App*

Bluetooth to control from Smartphone or tablet with VELVET Goya App*

Wire control

DMX-RDM through XLR-5 IN and through connectors

Art-Net through Ethernet RJ-45 connector (only STUDIO version).

Local control

The full color touchscreen simplifies any light, zoom or effects setting while two rotary knobs provide precise manual adjustments.

- Gels list are displayed as colors.
- White light or color adjustment presets are always visible on its real color.
- You can immediately save or load any preset including the beam light angle.
- You can instantly reset to 3200K or 5600K white light without any other modified parameter.

KOSMOS gives you immediate remote control over beam angle, color, effects or presets from your smartphone or tablet.

FIRMWARE UPDATES HISTORY

V01.04

new implementations

- Gels mode with library extension
- Gels mode with improved color accuracy
- Gels mode added new list of light sources
- PRESET displays the registered Gels parameters when saved
- Green/Magenta warning icon shows a green or magenta color warning
- Master/Slave mode implemented in DMX menu

V01.05

new implementations

- Implemented Effects Mode: 9 effects with multiple customizable parameters including any selectable color, Zoom In and Zoom Out adjustment, zoom speed to create any custom effect.
- “DEF” button for resetting the Effects settings to factory defaults
- PRESET button to save and load any custom FX settings
- DMX map updated with the implemented Effects
- New dynamic DMX Master mode: when receiving wireless DMX signal through LumenRadio, the fixture automatically sets itself as Master and through the DMX cable it can pass the parameters to the other fixtures that are in Slave (this can be disabled by reconfiguring the fixture as Slave).

Kosmos range models

Every KOSMOS color tunable Fresnel is offered in two different versions: LOCATION and STUDIO dustproof. The main differences are:

Location

VK400CNY

VELVET Kosmos
400 Color Location
without yoke

- Can be powered both AC (90-264 VAC) and DC (26-48V DC)
1x XLR-3 DC in connector
- Built-in LumenRadio for DMX-RDM wireless control



Studio

VK400CSTNY

KOSMOS 400
Color Studio
without yoke

- Must be exclusively powered on AC (90-264 VAC)
- 1x RJ45 connector for Ethernet wire control



VELVET KOSMOS 400 location (Ref: VK400CNY)

PARTS



1. 300mm/12" Borosilicate glass fresnel lens
2. Housing for VK42-BP (Battery mount adapter)
3. Touchscreen display
4. USB connectors
5. PowerCon TRUE 1 In & Out connectors
6. 8A AC fuse
7. Main power switch
8. 2x Rotary dials
9. XLR-5 DMX RDM In & Out connectors
10. Wireless functions antenna
11. XLR3 DC In connector

SPECIFICATIONS

OPTICAL SYSTEM	Motorized ZOOM Fresnel												
COLOUR TEMPERATURE	Continuously adjustable from 2500K to 10000K (100K increments)												
LIGHT INTENSITY	Smooth 0 to 100%, three selectable dimming curves												
FRESNEL LENS	Borosilicate glass Fresnel lens 300mm / 12"												
GREEN-MAGENTA	Continuously adjustable from Full green to Full minusgreen												
LOCAL CONTROL	2x rotary knobs and full-color touchscreen display												
WIRE CONTROL	Full DMX-RDM with XLR-5 In & Out connectors												
WIRELESS CONTROL	LumenRadio CRMX built-in, Wi-Fi Art-Net sCAN and Bluetooth, Android and iOS using VELVET Goya free charge app												
TLCI INDEX	3200K TLCI 96 / 5600K TLCI 98												
PHOTOMETRICS	<table border="0"> <tr> <td>50° - 3200K</td> <td>13° - 3200K</td> </tr> <tr> <td>3150 lux / 293 fc at 3 m / 9.8 feet</td> <td>13000 lux / 1208 fc at 3 m / 9.8 feet</td> </tr> <tr> <td>780 lux / 72 fc at 6 m / 20 feet</td> <td>3280 lux / 305 fc at 6 m / 20 feet</td> </tr> <tr> <td>50° - 5600K</td> <td>13° - 5600K</td> </tr> <tr> <td>4500 lux / 418 fc at 3 m / 9.8 feet</td> <td>19200 lux / 1784 fc at 3 m / 9.8 feet</td> </tr> <tr> <td>1180 lux / 110 fc at 6 m / 20 feet</td> <td>4960 lux / 461 fc at 6 m / 20 feet</td> </tr> </table>	50° - 3200K	13° - 3200K	3150 lux / 293 fc at 3 m / 9.8 feet	13000 lux / 1208 fc at 3 m / 9.8 feet	780 lux / 72 fc at 6 m / 20 feet	3280 lux / 305 fc at 6 m / 20 feet	50° - 5600K	13° - 5600K	4500 lux / 418 fc at 3 m / 9.8 feet	19200 lux / 1784 fc at 3 m / 9.8 feet	1180 lux / 110 fc at 6 m / 20 feet	4960 lux / 461 fc at 6 m / 20 feet
50° - 3200K	13° - 3200K												
3150 lux / 293 fc at 3 m / 9.8 feet	13000 lux / 1208 fc at 3 m / 9.8 feet												
780 lux / 72 fc at 6 m / 20 feet	3280 lux / 305 fc at 6 m / 20 feet												
50° - 5600K	13° - 5600K												
4500 lux / 418 fc at 3 m / 9.8 feet	19200 lux / 1784 fc at 3 m / 9.8 feet												
1180 lux / 110 fc at 6 m / 20 feet	4960 lux / 461 fc at 6 m / 20 feet												
COLOR CONTROL MODES	CTT, HSI, CTT + RGB, Gels and Effects with ZOOM in every Mode NOTE: base Kelvin white light can be set combined with any color												
BEAM ANGLE	13° in spot, 56° in flood. Motorized zoom with stepper motor												
DIMENSIONS	320x320x499mm / 12.6"x12.6"x19.6" (fixture) 320x533x499mm / 12.6"x21"x19.6" (fixture + yoke)												
WEIGHT	9.3 kg / 20.5 lbs (fixture) 9.8 kg / 22.6 lbs (fixture + yoke)												
POWER DRAW	400W												
AC POWER SUPPLY	90-264V AC 50/60Hz PowerCon TRUE1 In & Out												
DC POWER SUPPLY	26-48V DC XLR-3 IN connector												
LED RATED LIFE	(L70) exceeds 50,000 hours												
OUTPUT FREQUENCY	12,000 fps												
OPERATION TEMPERATURE	From -20°C to +45°C												
COOLING	Passive liquid cooling system into sealed 3D chamber with ultra silent fan												
PROTECTION	IP30, indoor or outdoor protected use												
LIGHT ENGINE	35mm full color spectrum R+G+B+W+CW VELVET ceramic LED												
CONSTRUCTION & FINISH	Fixture and yoke made of die-cast aluminum												

PHOTOMETRICS

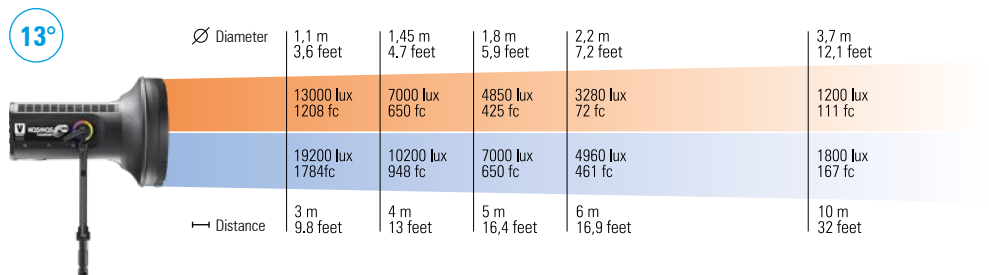
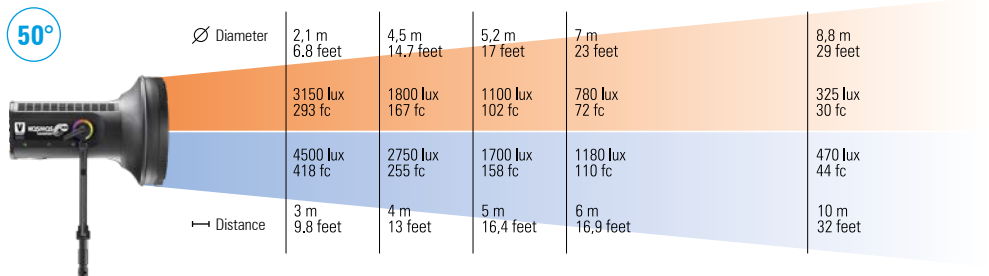

3200K
TLCI 96

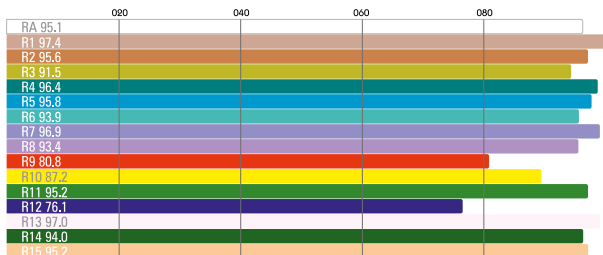
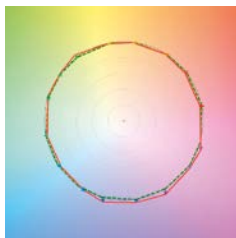

5600K
TLCI 98

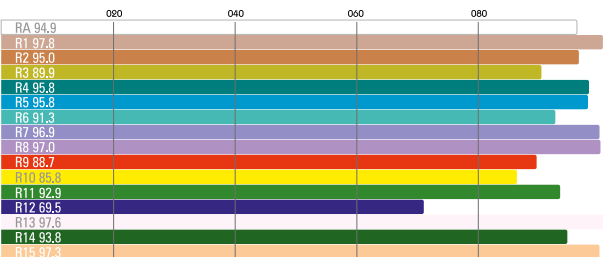
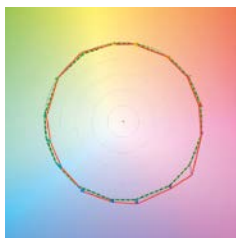

POWER OPTIONS

The KOSMOS 400 Location can be powered by AC power, by any battery from 26 to 48 VDC or by using two Vlock or two Gold batteries and it delivers the same full output both AC and DC powered.

BATTERY POWER 24 to 48 VDC

Connect any battery from 26 to 48 VDC to the XLR3 connector.

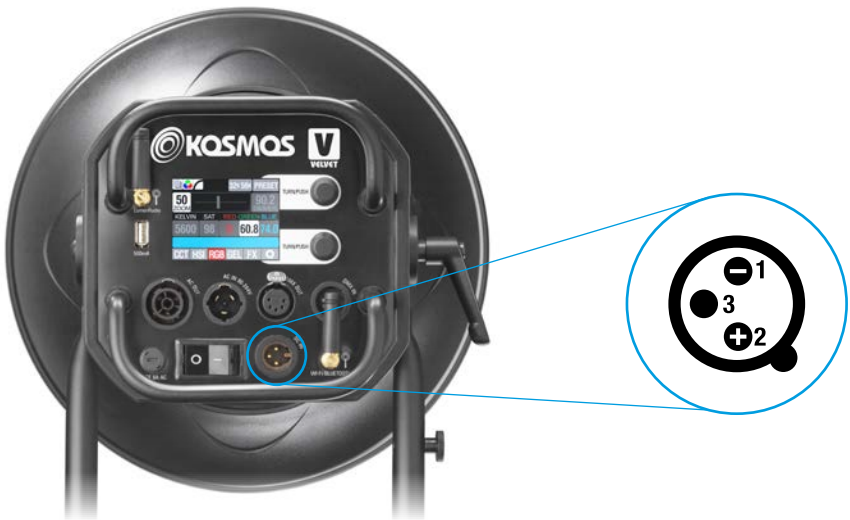

When powering VELVET KOSMOS Location from an external battery through the XLR3 connector check that the pin-out of the battery matches the pin-out of the KOSMOS as shown in the pin-out picture at the bottom of the fixture. Wrong assigned pin-outs can damage the KOSMOS Location and or the battery.



The KOSMOS Location switches off when the battery voltage drops below 26 V DC. The fixture will be damaged when the battery voltage exceeds 50 VDC. To ensure maximum performance of the equipment use only high-load capacity batteries with a high continuous draw meaning a Discharge Current of at least 10A.

DOUBLE V-LOCK AND DOUBLE GOLD BATTERY ADAPTERS

VELVET KOSMOS Location can also be directly powered with two 14.4V Vlock or Gold batteries using VELVET Double Vlock or Gold plate delivering full power light around one hour (200Wh 14.4V x 2).

Use batteries of at least 200Wh capacity each of them and to ensure maximum performance of the fixture use only high-load capacity batteries with a high continuous draw meaning a Discharge Current of at least 10A.

Attach the quick link Double Vlock or Gold plate by aligning the center pin of the mounting plate to the center hole on the fixture docking plate. Rotate the Double Vlock or Gold plate clockwise until the four shoulder rivets drop into their receptacles. A locking pin will snap into place when the plate is properly locked. Connect the XLR3 to the connector.



Secure the Vlock or Gold plate by inserting the locking pin into place.

Weatherproof models accessories

LIGHT ENGINE

VK400C-LED

VELVET KOSMOS 400 V5LED
color ceramic light engine

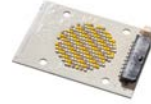

RIGGING

VK42-YTK

Manual Operated yoke Kit
for KOSMOS with Euro28mm
junior pin



BATTERY ADAPTERS

VK42-BP

Fixed battery plate KIT to
install quick link adapter.



VE-HS

Hexagonal baby pin to mount
EVO and KOSMOS batteries
plate on stand mast through
superclamp



VE-DVLOCKIP

Double V-lock battery adapter
with XLR3 IP54 connector on
quick link mount



VE-DGOLDIP

Double Gold battery adapter
with XLR3 connector on quick
link mount



BEAM CONTROL

VK400-RB

KOSMOS 400 4 folding barndoors kit



VK400-RB8

KOSMOS 400 8 folding barndoors kit



VK400-FF

KOSMOS 400 filter frame



VK400-SB

DopChoice Snapbag light box for KOSMOS 400



VK400-SGxSB

DopChoice 40° Foldable Snapgrid KOSMOS 400.



VK400-SL

DopChoice large Lantern dome for KOSMOS 400.



TRANSPORT

VK400-CASE

Flight case with 2 wheels for KOSMOS 400 kit



REMOTE CONTROL

VE-ROUTER

VELVET Wi-Fi router to remotely control KOSMOS



CABLES

CAB-XLR3DCC4.5M

DC extension cable 4,5 meters / 15 feet XLR3



CAB-PWC2MTRUE

PowerCon TRUE1 daisy-chain cable 2m / 6 feet for AC with 2 aerial connectors TRUE1 In & Out



CAB-PWC4MTRUE

PowerCon TRUE1 daisy-chain cable 4m / 12 feet for AC with 2 aerial connectors TRUE1 In & Out



DMX-DMX3M

DMX daisy-chain cable 3m / 10 feet



SLI-200000FS

Safety cable (1 meter)



VELVET KOSMOS 400 Studio (Ref: VK400CSTNY)

PARTS



- 1. 300mm/ 12" Borosilicate glass fresnel lens
- 2. Touchscreen display
- 3. USB connectors
- 4. POWERCON TRUE 1 In & Out connectors
- 5. 8A AC fuse
- 6. Main power switch
- 7. 2x Rotary dials
- 8. XLR-5 DMX RDM In & Out connectors
- 9. Wireless functions antenna
- 10. Ethernet Art-Net RJ-45 connector

SPECIFICATIONS

OPTICAL SYSTEM	Motorized ZOOM Fresnel												
COLOUR TEMPERATURE	Continuously adjustable from 2500K to 10000K (100K increments)												
LIGHT INTENSITY	Smooth 0 to 100%, three selectable dimming curves												
LIGHT APERTURE	Borosilicate glass Fresnel lens 300mm / 12"												
GREEN-MAGENTA	Continuously adjustable from Full green to Full minusgreen												
LOCAL CONTROL	2x rotary knobs and full-color touchscreen display												
WIRE CONTROL	Full DMX-RDM with XLR-5 In & Out connectors												
WIRELESS CONTROL	Wi-Fi Art-Net sCAN and Bluetooth, Android and iOS using VELVET Goya free charge app												
TLCI INDEX	3200K TLCI 96 / 5600K TLCI 98												
PHOTOMETRICS	<table border="0"> <tr> <td>50° - 3200K</td> <td>13° - 3200K</td> </tr> <tr> <td>3150 lux / 293 fc at 3 m / 9.8 feet</td> <td>13000 lux / 1208 fc at 3 m / 9.8 feet</td> </tr> <tr> <td>780 lux / 72 fc at 6 m / 20 feet</td> <td>3280 lux / 305 fc at 6 m / 20 feet</td> </tr> <tr> <td>50° - 5600K</td> <td>13° - 5600K</td> </tr> <tr> <td>4500 lux / 418 fc at 3 m / 9.8 feet</td> <td>19200 lux / 1784 fc at 3 m / 9.8 feet</td> </tr> <tr> <td>1180 lux / 110 fc at 6 m / 20 feet</td> <td>4960 lux / 461 fc at 6 m / 20 feet</td> </tr> </table>	50° - 3200K	13° - 3200K	3150 lux / 293 fc at 3 m / 9.8 feet	13000 lux / 1208 fc at 3 m / 9.8 feet	780 lux / 72 fc at 6 m / 20 feet	3280 lux / 305 fc at 6 m / 20 feet	50° - 5600K	13° - 5600K	4500 lux / 418 fc at 3 m / 9.8 feet	19200 lux / 1784 fc at 3 m / 9.8 feet	1180 lux / 110 fc at 6 m / 20 feet	4960 lux / 461 fc at 6 m / 20 feet
50° - 3200K	13° - 3200K												
3150 lux / 293 fc at 3 m / 9.8 feet	13000 lux / 1208 fc at 3 m / 9.8 feet												
780 lux / 72 fc at 6 m / 20 feet	3280 lux / 305 fc at 6 m / 20 feet												
50° - 5600K	13° - 5600K												
4500 lux / 418 fc at 3 m / 9.8 feet	19200 lux / 1784 fc at 3 m / 9.8 feet												
1180 lux / 110 fc at 6 m / 20 feet	4960 lux / 461 fc at 6 m / 20 feet												
COLOR CONTROL MODES	CTT, HSI, CTT+RGB, GELS and EFFECTS with ZOOM in every mode NOTE: base Kelvin white light can be set combined with any color												
BEAM ANGLE	13° in spot, 56° in flood. Motorized zoom with stepper motor												
DIMENSIONS	320x320x499mm / 12.6"x12.6"x19.6" (fixture) 320x533x499mm / 12.6"x21"x19.6" (fixture + yoke)												
WEIGHT	9.3 kg / 20.5 lbs (fixture) 9.8 kg / 22.6 lbs (fixture + yoke)												
POWER DRAW	400W												
AC POWER SUPPLY	90-264V AC 50/60Hz PowerCon TRUE1 In & Out												
DC POWER SUPPLY	26-48V DC XLR-3 IN connector												
LED RATED LIFE	(L70) exceeds 50,000 hours												
OUTPUT FREQUENCY	Over 12,000 fps												
OPERATION TEMPERATURE	From -20°C to +45°C												
COOLING	Passive liquid cooling system into sealed 3D chamber with ultra silent fan												
PROTECTION	IP30, indoor or outdoor protected use												
LIGHT ENGINE	35mm full color spectrum R+G+B+W+CW VELVET ceramic LED												
CONSTRUCTION & FINISH	Fixture and yoke made of die-cast aluminum												

PHOTOMETRICS

50°

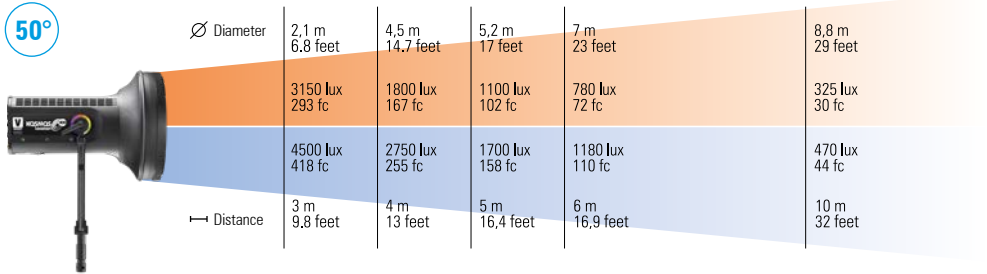

13°

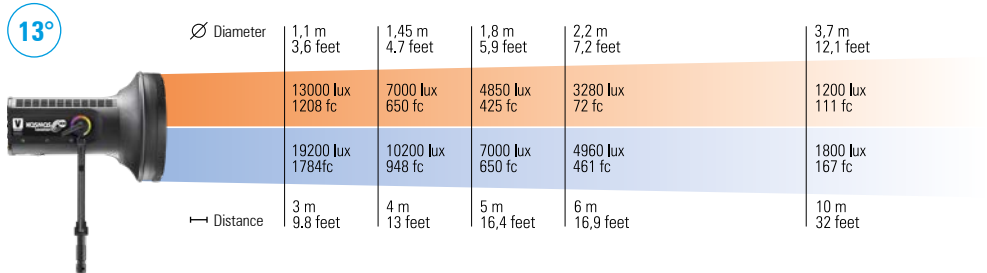

**3200K
TLCI 96**

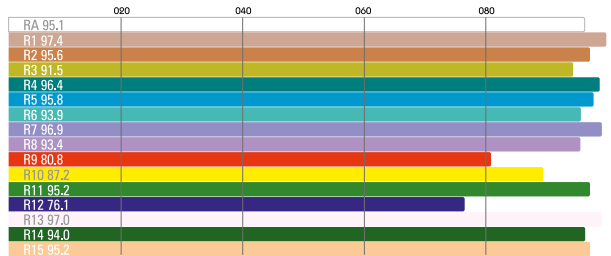
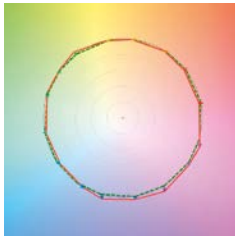

**5600K
TLCI 98**

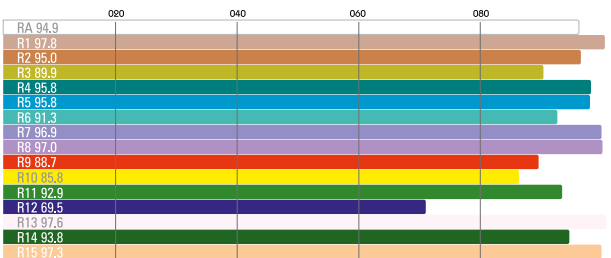
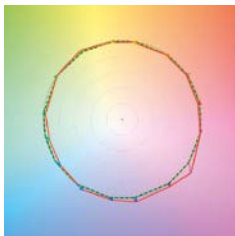

POWER OPTIONS

AC POWER 90 to 264 VAC

The KOSMOS 400 Studio can be exclusively powered by AC power. Connect the power cable to the PowerCon TRUE1 TOP and the power plug with a mains power outlet.



High light beam intensity: The lamp head is equipped with power LED. Due to their high light-output intensity don't stare directly into the light source.

Always connect the KOSMOS direct to AC power. Do not connect the fixture to a dimmer system. Doing so will damage the fixture



Grounding: In order to protect against risk of electric shock, the AC installation should be properly grounded. The AC mains power supply must be fitted with a fuse or circuit breaker and ground-fault (earth-fault) protection. Defeating the purpose of the grounding type plug will expose you to the risk of electric shock.

Weatherproof models accessories

LIGHT ENGINE

VK400C-LED

VELVET KOSMOS 400 V5LED
color ceramic light engine

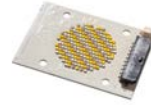

RIGGING

VK42-YPO

Pole Operated yoke Kit for
KOSMOS 400



VK42-YTK

Manual Operated yoke Kit
for KOSMOS with Euro28mm
junior pin



BEAM CONTROL

VK400-RB

KOSMOS 400 4 folding
barndoors kit



VK400-RB8

KOSMOS 400 8 folding
barndoors kit



VK400-SB

DopChoice Snapbag light box
for KOSMOS 400



VK400-SGxSB

DopChoice 40° foldable
Snapgrid KOSMOS 400.

VK400-SL

DopChoice large Lantern dome for KOSMOS 400.

**REMOTE CONTROL****VE-ROUTER**

VELVET Wi-Fi router to remotely control KOSMOS

**CABLES****CAB-XLR3DCC4.5M**

DC extension cable 4,5 meters / 15 feet XLR3

**CAB-PWC2MTRUE**

PowerCon TRUE1 daisy-chain cable 2m / 6 feet for AC with 2 aerial connectors TRUE1 In & Out

**CAB-PWC4MTRUE**

PowerCon TRUE1 daisy-chain cable 4m / 12 feet for AC with 2 aerial connectors TRUE1 In & Out

**DMX-DMX3M**

DMX daisy-chain cable 3m / 10 feet

**SLI-200000FS**

Safety cable (1 meter)



Placing into operation

YOKE TO FIXTURE ASSEMBLING

VK42-YTK

Manual Operated yoke
Kit for KOSMOS with
Euro28mm/junior pin

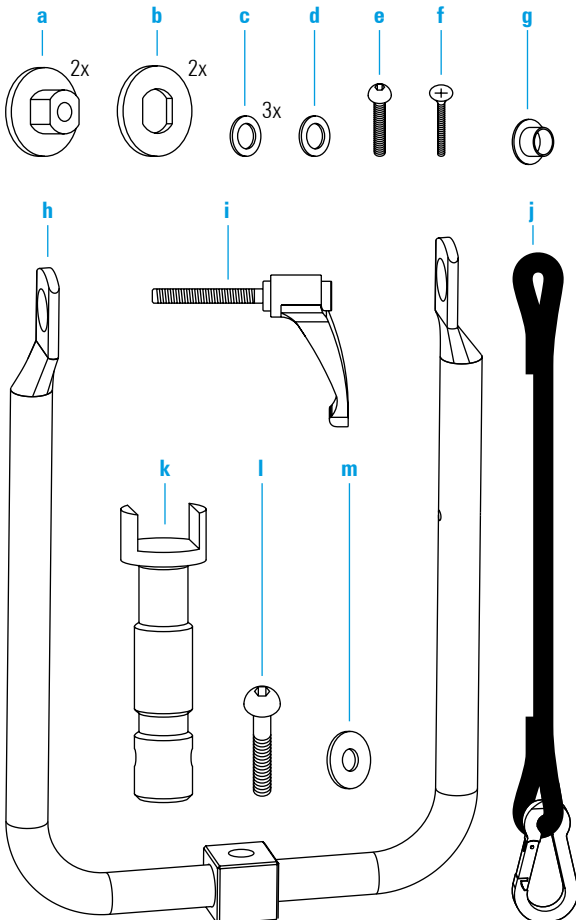

Yoke assembling pieces

- a. **M4300P17S000** Nylon side bushing for KOSMOS yoke
- b. **TOR-KWS** Ferodo washer for KOSMOS yoke
- c. **TOR-D2093BM8** Conical M8 washer
- d. **TOR-D125M8T** Black M8 standard washer
- e. **TOR-D7380M8X30T** Allen socket head cap screw M80x30
- f. **TOR-D965M5X30T** BlackPhillips countersunk screw M5x30
- g. **TOR-D466M5** Knurled nut high form M5
- h. **M4300P100000** KOSMOS tubular yoke with squared stud
- i. **M3800P190000** KOSMOS adjustable knob M8x30
- j. **M4300P56002** Nylon safety cable for KOSMOS yoke

Spigot assembling pieces

- k. **EV-EURO28TC** Spigot Euro 28mm/junior pin for tubular yoke
- l. **TOR-D7380M8X40T** Allen socket head cap screw M8x40
- m. **TOR-DIN9021M8T** Metallic M8 washer

Steps scheme

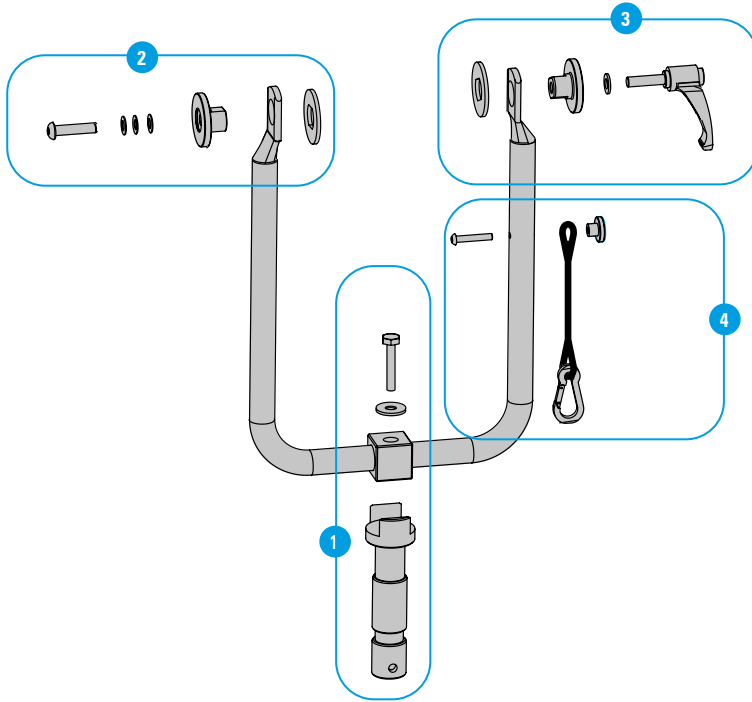

STEP 1

Spigot assembling

Use a mallet or hammer to press the spigot (k) into the square housing of the tubular yoke (h). Secure the assembly with the washer (m) and screw (l).

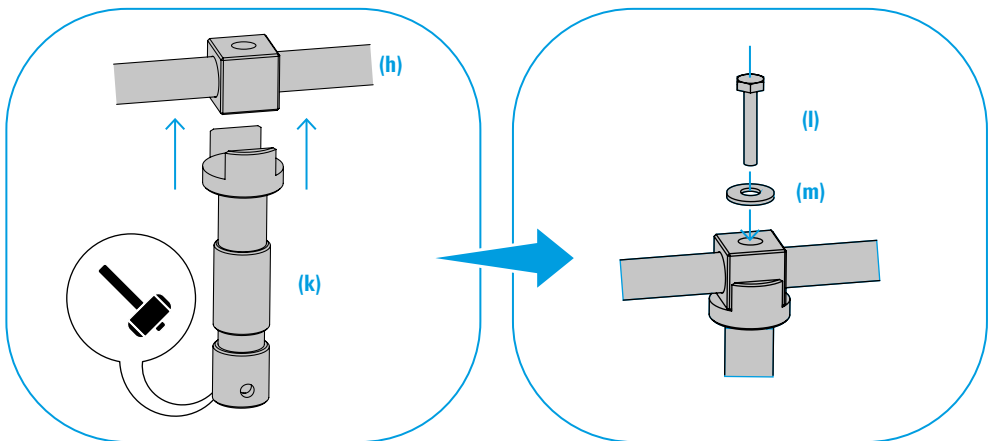

STEP 2

Yoke assembling

Place the ferodo washer **(b)** on the inside of the yoke **(h)**. Place the side bushing **(a)** and the three conical washers **(c)** on the outside and use the allen screw **(e)** to fix the parts with the fixture and select the desired friction.

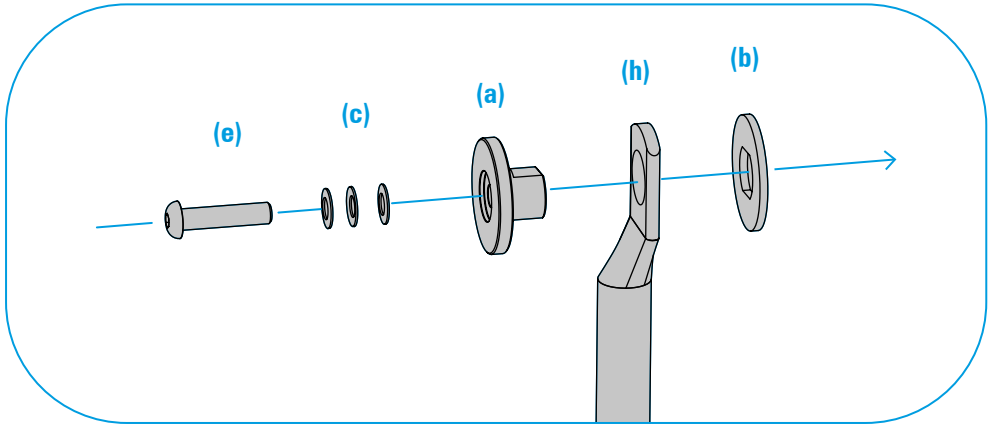

STEP 3

Yoke assembling

Place the ferodo washer **(b)** on the inside of the yoke **(h)**. Place the side bushing **(a)** and the standard washer **(d)** on the outside and use the adjustable handle **(i)** to fix the parts with the fixture.

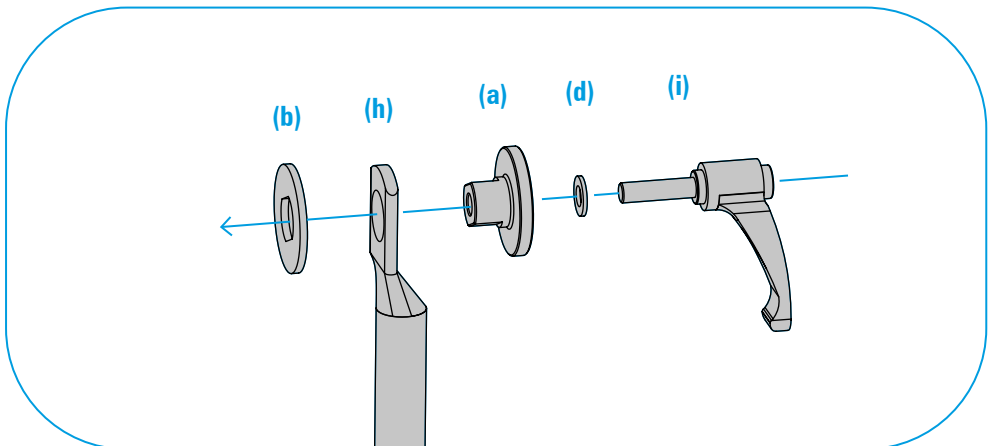

STEP 4

Safety cable

Use the screw (f) on the inside of the yoke and the knurled nut (g) on the outside to attach the safety cable (j) to the yoke.

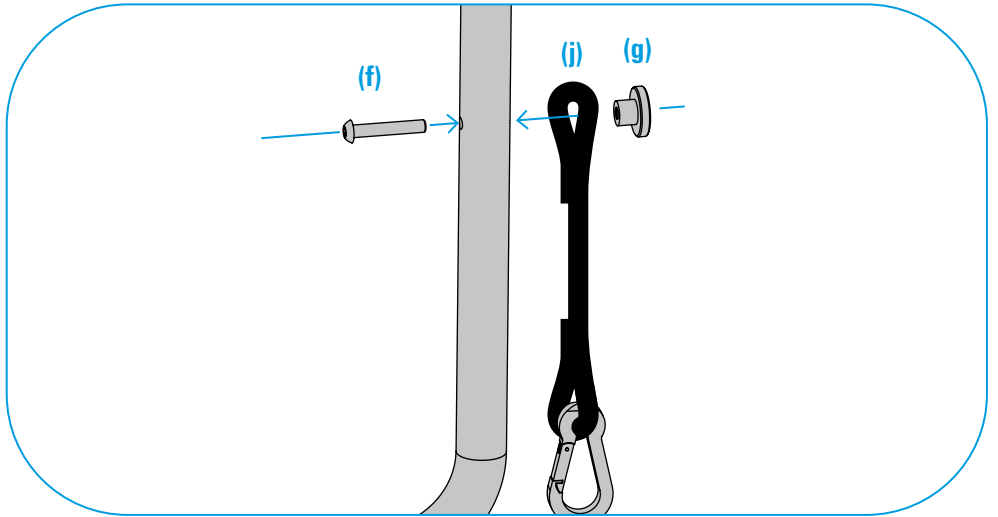

POLE OPERATED YOKE TO FIXTURE ASSEMBLING

VK42-YPO

Pole Operated yoke Kit for
KOSMOS 400

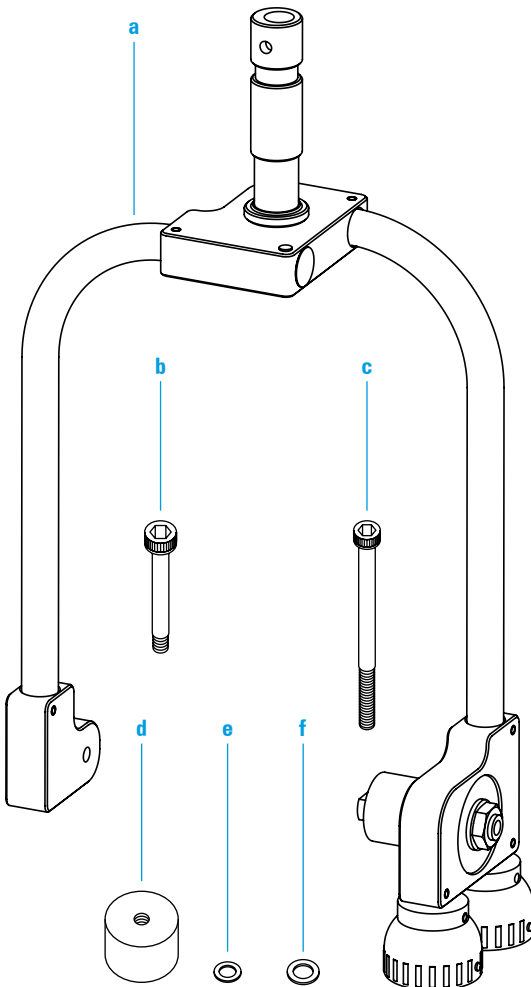

- a. **KOSMOS-Y-POLEOP** KOSMOS-Y-POLEOP
- b. **TOR-I7379M8X55** M8x55 Allen screw
- c. **TOR-D912M8X100T** M8x100 Allen screw
- d. **Q400P170001** Nylon spacer bushing for PO KOSMOS yoke
- e. **TOR-D125M8T** Black M8 standard washer
- f. **TOR-D125M10T** Black M10 standard washer

STEP 1

Place the KOSMOS fixture by positioning the PO loop gearbox **(a)** on the right side of the unit looking at it from the back.

Use the spacer bushing **(d)** on the inside left side of the yoke and fix the assembly with the washer **(f)** and the M8x55 screw **(b)** on the outside.

Fix the yoke with washer **(e)** and M8x100 screw **(c)** on the other side.

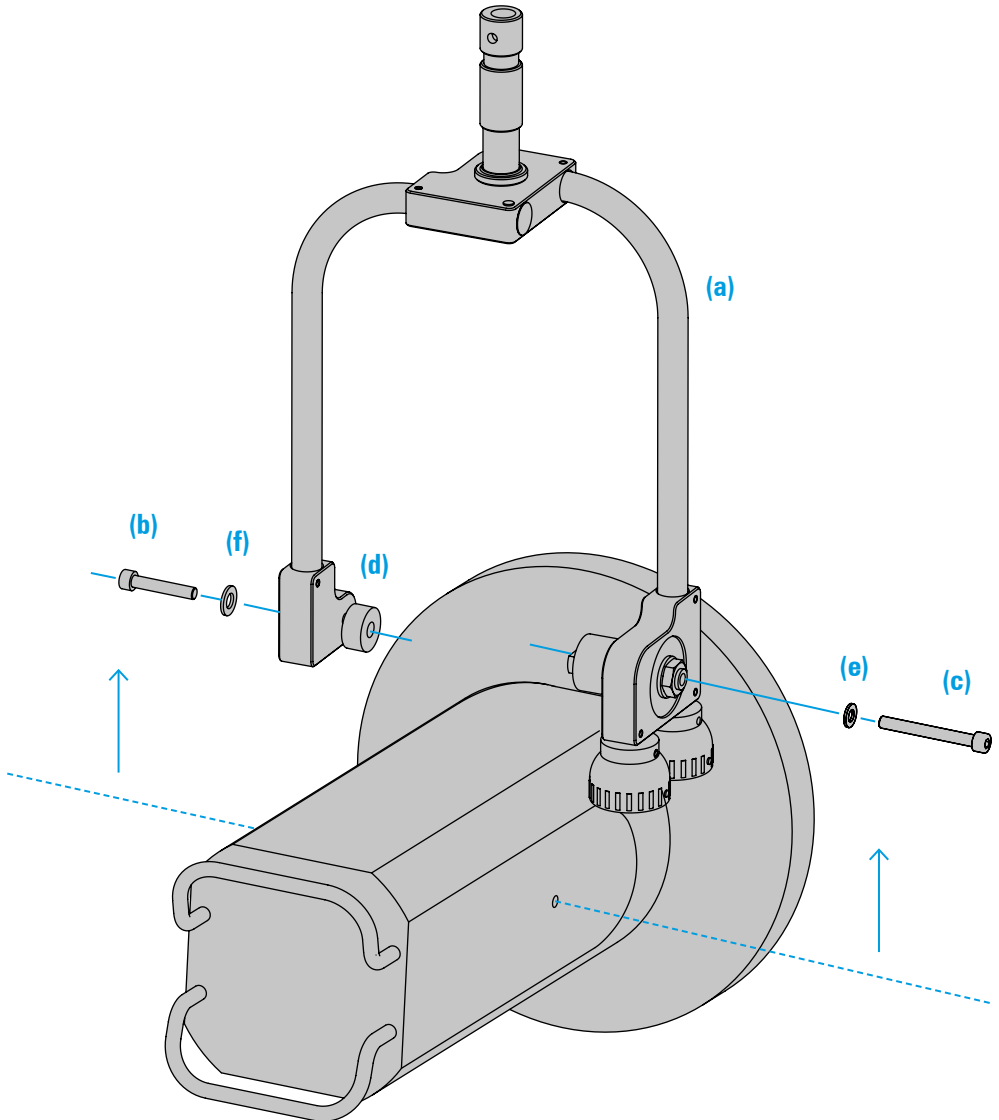

MOUNTING AND SECURITY

VELVET KOSMOS fixtures have been designed to be easily installed and rigged up on studio, special locations and vehicles.



When a VELVET KOSMOS and any other component is mounted in a hanging position it must be secured with a safety cable rated at a minimum of ten times the weight of the light fixture including its accessories.

Secure the KOSMOS with a safety cable from the mounting structure or truss through the fixture yoke.

Accessories installation

BARNDOORS INSTALLATION

VK400-RB

KOSMOS 400 4 folding barndoors kit

VK400-RB8

KOSMOS 400 8 folding barndoors kit

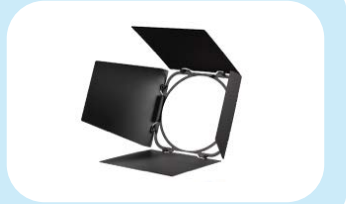

STEP 1

Snap the upper visor hook into the metal notch at the top of the equipment lens.



STEP 2

Press the metal socket on the bottom of the KOSMOS lens to engage the bottom of the visor. Release to allow the spring mechanism to exert pressure to secure the assembly.

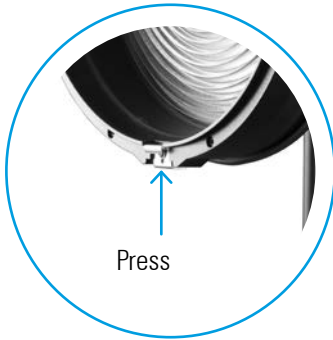

SNAPBAG, SNAPGRID AND LANTERN INSTALLATION

VK400-SB

Snapbag Medium



VK400-SGxSB

DopChoice 40° foldable Snapgrid



VK400-SL

DopChoice large Lantern



Scan the QR code to access the installation instructions on our Youtube channel.

[Video link](#)



Diagrams

VELVET KOSMOS + MO Yoke

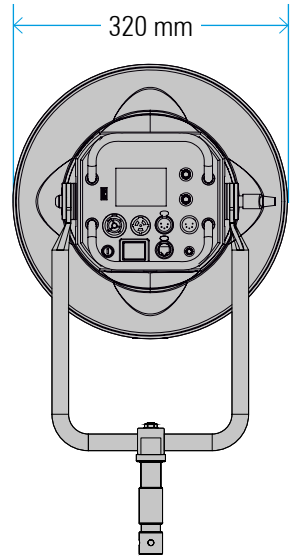
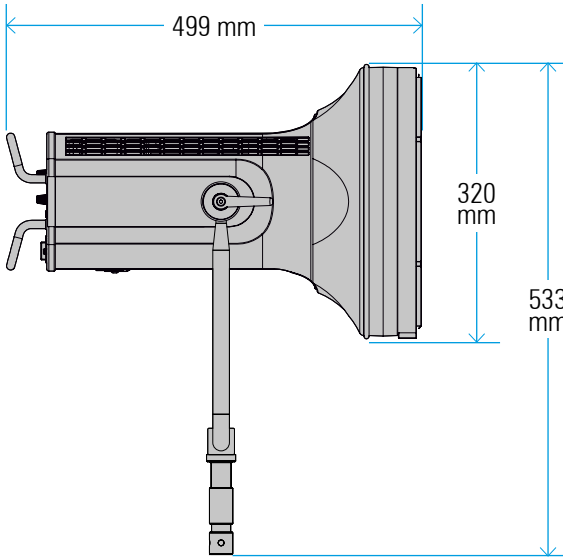

VELVET KOSMOS + PO Yoke

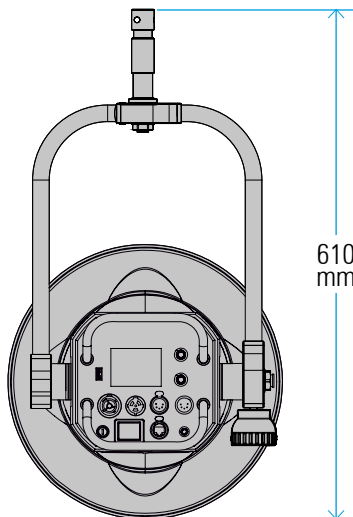

Menu overview

POWER ON/OFF

After switching on the KOSMOS initializes for a few seconds to be ready for operation through its full-color touchscreen plus two rotary knobs.

The KOSMOS will show the last white light, color and zoom settings and the source will emit light only as per the last setting



High light beam intensity: The lamp head is equipped with power LED. Due to their high light-output intensity don't staredirectly into the light source.

DISPLAY OVERVIEW

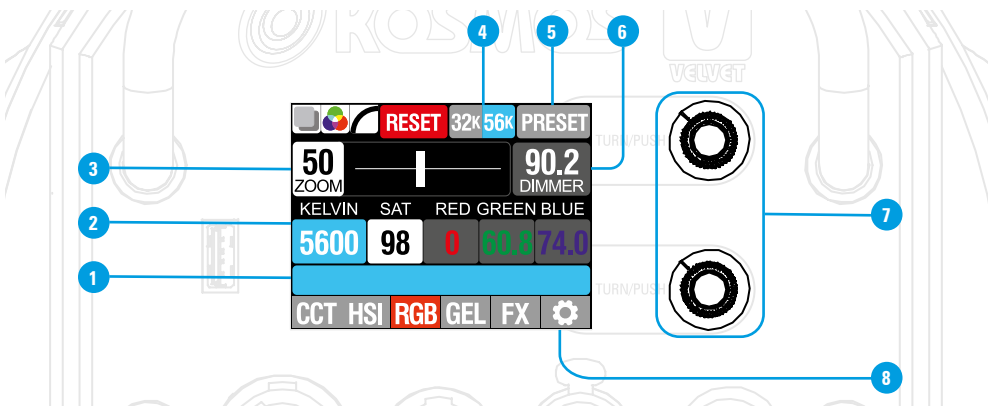

* Main function / *Secondary function*

- | | |
|-----------------------------|--|
| COLOR MODES | 1. Takes you to CTT white mode, HSI, RGB color mode, GELS selection and EFFECTS selection mode. |
| KELVIN | 2. Once selected you can precisely adjust the KELVIN value by rotating the Bottom Control Knob. |
| ZOOM BUTTON / SLIDER | 3. Once selected you can precisely adjust the light beam angle by rotating the Top Control Knob / Quick tactile ZOOM adjustment / <i>Shows the actual light beam angle.</i> |
| 32/56K | 4. Goes to preset 3200K, 5600K and back to the last white light and color settings. |
| PRESET | 5. Lets you save or load any white light or color settings combined with zoomactual white light, color and ZOOM settings. |
| DIMMER | 6. Once selected you can precisely adjust the light Intensity by rotating the Top Control Knob / <i>Shows the actual light numerical value in percentage.</i> |
| CONTROL KNOBS | 7. Manually and precisely adjust the selected option / <i>Press to toggle among selectable options within the top row/top encoder and bottom row/bottom encoder.</i> |
| SETTINGS | 8. Press to go to SETTINGS mode. |

DISPLAY STRUCTURE

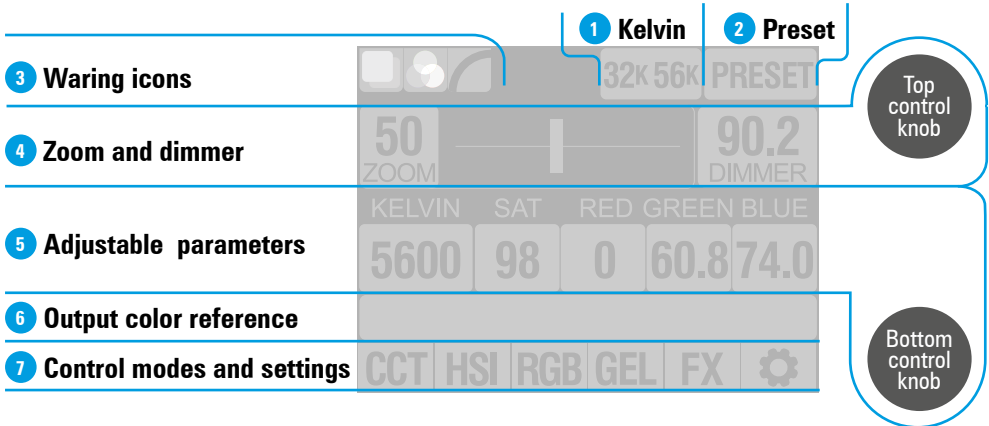

- 1. Kelvin** By pushing once resets to White Light 3200K, pushing again resets to 5600K and by pushing a third time goes back to the last white light or color setting.
- 2. Preset** Press the *PRESET* button to display the Menu of the Presets generated and saved by the user in the equipment. It saves both the light intensity values, as well as colorimetry and beam angle.
- 3. Warning icons** Inform about the global status of the fixture. When any icon is turned on means that the function is activated (they appear as a colored icon), otherwise the feature is disabled (they appear as a gray icon). The warning icons are Green/Magenta in CCT Mode or Color in HSI or GELS mode.
- 4. Zoom and Dimmer** Changes the beam angle in two ways: 1. Push the top Control Knob to select *ZOOM*, then turn the knob to precisely adjust the beam angle / 2. Drag with your finger the *ZOOM* slider to quickly change the beam angle. Push the top Control Knob to select *DIMMER*, then turn the knob to change the intensity value.
*The rotary knobs are progressive with an acceleration curve from 0 to 100, if they are turned slowly the parameters vary little by little, if they are turned quickly the changes are fast
- 5. Adjustable parameters** The adjustable options will vary depending on the control mode selected. To select any option you can push the bottom Control Knob to navigate through the adjustable parameters or simply touch over the desired parameter and adjust the numerical value using the corresponding encoder.

6. Color area

The color area over the control modes buttons shows a real time emulation of every color adjustment as a visual reference of the light emitted by the fixture.

7. Control Modes and Settings

The different Control Modes allow you to select the colorimetry parameters through the CCT, HSI, RGB and GELS modes.

Control Modes			
CTT	HSI	RGB	GELS
Zoom Dimmer Kelvin Green/Magenta	Zoom Intensity Kelvin Saturation Hue	Zoom Intensity Kelvin Saturation Red/Green/Blue	Gel Zoom Intensity Kelvin Saturation Red Green Blue

Settings			
DMX-RDM		CONTROL REMOTO	
Address		LumenRadio (only KOSMOS Location)	DMX address DMX mode State DMX button
DMX lost behavior	Hold data Go to local		Set Set Unlinked/ connected Change address change mode
DMX mode	CTT 8 bit CTT + HSI 8 bit CTT + RGB 8 bit RGB+ 8 bit GELS 8 bit CHANGING 8 bit CTT 16 bit CTT + HSI 16 bit CTT + RGB 16 bit RGB+ 16 bit GELS 16 bit CHANGING 16 bit	WI-FI	IP MAC RSSI Status GOYA App Unconnected/ connected Push to use Goya
DMX contol	Slave Master	BLUETOOTH	Status GOYA App Unconnected/ connected Push to use Goy
		ETHERNET (only KOSMOS Studio)	

DIMMING CURVE	
Dimming curve	Linear (default) Logarithmic 1 Exponential

FAN	
Fan mode	Dynamic Silence Full speed

FAN	
Fan mode	Dynamic Silence Full speed

CONTROL OPTIONS

The KOSMOS can be fully, quickly and easily controlled in any possible way. Locally, through DMX connector, wirelessly. From your smartphone or tablet using the VELVET Goya app or with third-party applications.

Local control • On-board control with full color touchscreen plus two rotary knobs

WIRE CONTROL • DMX-RDM through XLR-5 in and through connectors
• Art-Net through Ethernet RJ-45 connector (only KOSMOS Studio)

WIRELESS CONTROL • DMX-RDM with CRMX LumenRadio (only KOSMOS Location)
• Art-Net through Wi-Fi
• Bluetooth

CONTROL PRIORITIES. The following rules whenever you will control KOSMOS fixture through more than one control method

Wire Art-Net	Priority 1
Wire DMX-RDM	Priority 2
Wireless LumenRadio DMX-RDM	Priority 3
Wireless Wi-fi Art-Net	Priority 4
On-board control	Priority

In case of signal loss you can set the behavior of the fixture.

To set the loss behavior go to DMX or LumenRadio Lost behavior on the Settings menu.

Zoom and Control Modes

ZOOM/BEAM ANGLE ADJUSTMENT

You can locally adjust the beam angle in two ways:

- Push the *ZOOM* button and directly set the beam angle by rotating the top knob.
- For quick settings directly slide the *ZOOM* slider
- Bluetooth

The *ZOOM* can be adjusted at any moment combined with any control mode

CCT MODE / WHITE LIGHT

1. Push *DIMMER* button and directly set the intensity by rotating the top knob.
2. Push the *KELVIN* button and directly set the color temperature value by rotating the bottom knob.
3. Push the *GREEN-MAGENTA* button and directly set the correction value by rotating the bottom knob.

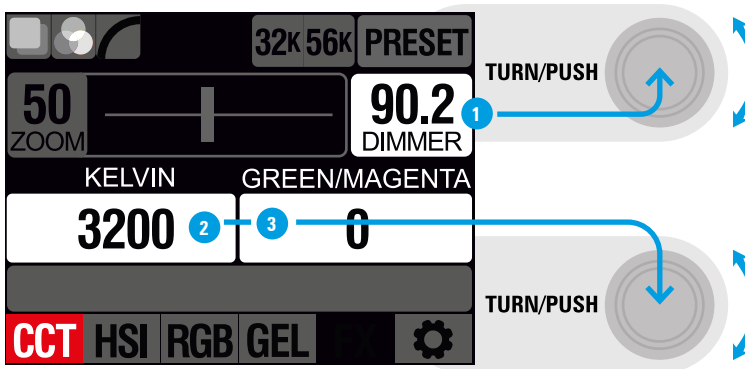

NOTE

Any time GREEN-MAGENTA will be set out of zero the G/M icon will change to ON as a warning that standard white light is offset.



HSI MODE / COLOR LIGHT

1. Push *DIMMER* button and directly set the intensity by rotating the top knob.
2. Push the *KELVIN*, *SATURATION* or *HUE* buttons and directly set the desired value by rotating the bottom knob.

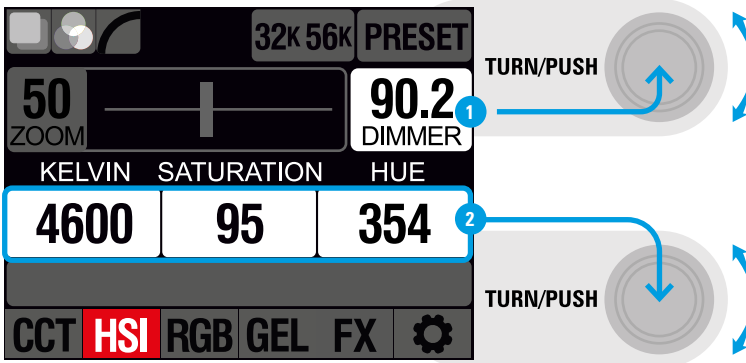

NOTE

When the Saturation value is 0, the light emitted by KOSMOS is just white light with the Color Temperature setting selected and shown on the display, and therefore HUE will have no effect.

When the Saturation value is between 1 and 100 the light emitted by KOSMOS includes color tint and therefore HUE will be active.

Any time saturation will be set out of zero the RGB icon will change black and white to color as a warning that standard white light is offset

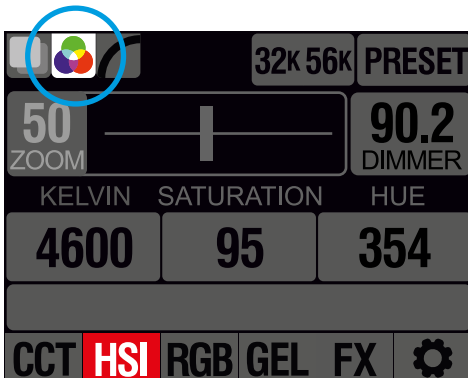

RGB MODE

1. Push *DIMMER* button and directly set the intensity by rotating the top knob.
2. Push the *KELVIN*, *SATURATION* or *RED*, *GREEN* and *BLUE* buttons and directly set the desired value by rotating the bottom knob

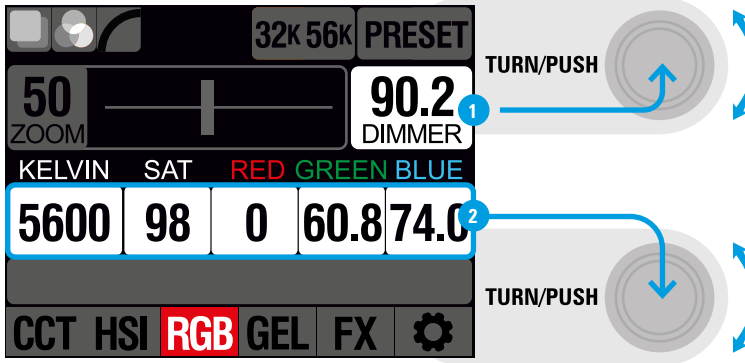

NOTES

When the Saturation value is 0, the light emitted by KOSMOS is just white light with the Color Temperature setting selected and shown on the display, and therefore RED, GREEN and BLUE will have no effect.

When the Saturation value is between 1 and 100 the light emitted by KOSMOS includes color tint and therefore Red, Green and Blue will be active.

Any time saturation will be set out of zero and also Red, Green or Blue will be set out of zero the RGB icon will change to ON as a warning that standard white light is offse

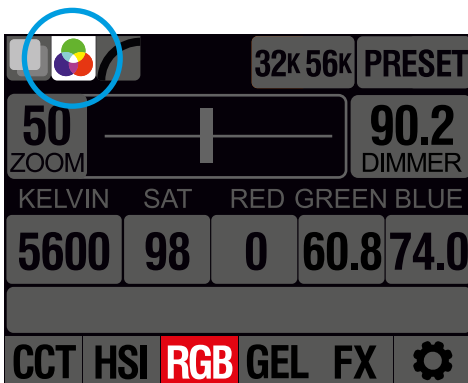

GELS MODE / COLOR LIGHT

On *GEL* Mode you can easily select any color filter from a wide and user-friendly library.

- Sort the filters on alphabetical or on color order.
- Display each filter showing its number, name and also its actual color.
- Set the color temperature of the virtual white light source to 2500K or 10000K.
- Edit and create your own new filter by adjusting: intensity, color temperature from 2500 to 10000K, Saturation, Red, Green and Blue.

TO EDIT A GEL

1. Select a base filter to work on and directly modify *KELVIN*, *SATURATION* and individual *RGB* parameters.
2. The result is shown live and emulated on the color band.
3. Press *PRESET* and the list of presets will be displayed on the screen. Select one and overwrite the preset by pressing *SAVE* and confirm.

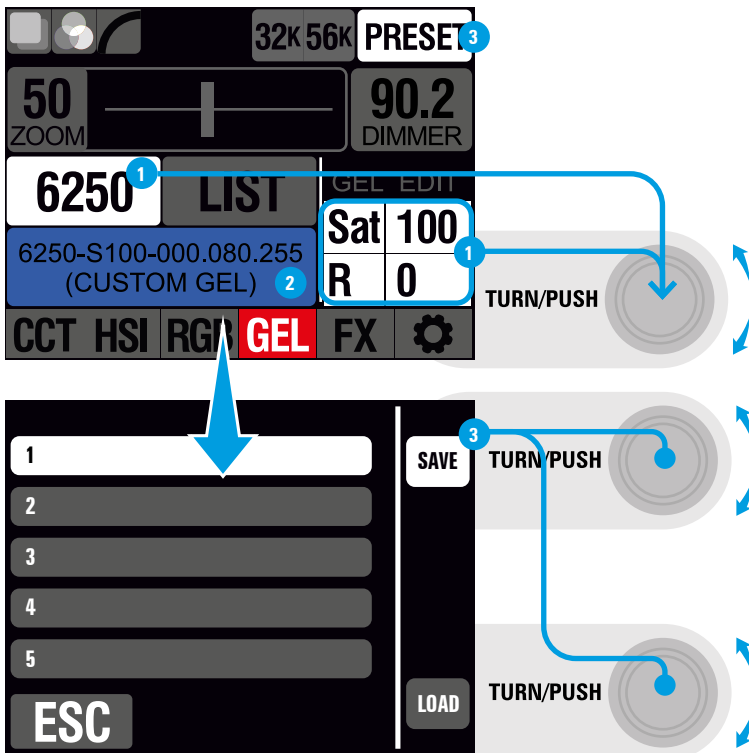

GELS MODE / LIST SORTING

- 1. Press *LIST* button to choose among “L” filter library, “R” filter library of Light sources library. You also have a small library of standard light sources.
- 2. Sort the filters list on alphabetical or on color order. Press *VIEW LIST* button.
- 3. Scroll up/down using any knob button and select the Gel pushing the knob button.

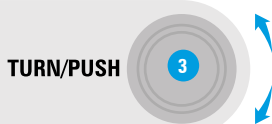
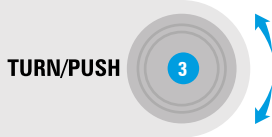
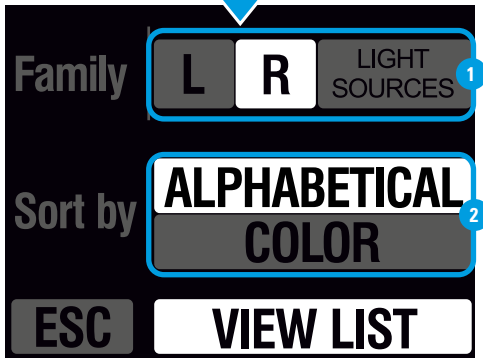

"L" GEL LIST (Page 01/03)

002 Rose Pink	036 Medium Pink	102 Light Amber	127 Smokey Pink
003 Lavender Tint	046 Dark Magenta	103 Straw	128 Bright Pink
004 Med.Bastard Amb.	048 Rose Purple	104 Deep Amber	131 Marine Blue
007 Pale Yellow	052 Light Lavender	106 Primary Red	134 Golden Amber
008 Dark Salmon	053 Paler Lavender	107 Light Rose	135 Deep Golden Amb.
009 Pale Amber Gold	058 Lavender	108 English Rose	136 Pale Lavender
010 Medium Yellow	061 Mist Blue	109 Light Salmon	137 Special Lavender
013 Straw Tint	063 Pale Blue	110 Middle Rose	138 Pale Green
017 Surprise Peach	068 Sky Blue	111 Dark Pink	140 Summer Blue
019 Fire	075 Evening Blue	113 Magenta	142 Pale Violet
020 Medium Amber	079 Just Blue	115 Peacock Blue	143 Pale Navy Blue
021 Gold Amber	085 Deeper Blue	117 Steel Blue	144 No Color Blue
022 Dark Amber	088 Lime Green	118 Light Blue	147 Apricot
024 Scarlet	089 Moss Green	120 Deep Blue	148 Bright Rose
025 Sunset Red	090 Dark Yellow Grn.	121 L. Green	151 Gold int
026 Bright Red	100 Spring Yellow	122 Fern Green	152 Pale Gold
035 Light Pink	101 Yellow	124 Dark Green	153 Pale Salmon

“L” GEL LIST (Page 02/03)

154 Pale Rose	188 Cosmet.Highlight	207 Full CTO + .3 ND	243 L. Fluoresc.3600K
156 Chocolate	189 Cosm.Silver Moss	208 Full CTO + .6 ND	244 L. Plus Green
157 Pink	191 Cosmet.Aqua Blue	212 L.C.T.Yellow(Y1)	245 1/2 Plus Green
159 No Color Straw	192 Flesh Pink	213 White Flame Grn.	246 1/4 Plus Green
161 Slate Blue	194 Surprise Pink	217 Blue Diffusion	247 L. Minus Green
162 Bastard Amber	195 Zenith Blue	218 1/8 CTB	248 1/2 Minus Green
164 Flame Red	196 True Blue	219 L.Fluoresc.Green	249 1/4 Minus Green
165 Daylight Blue	197 Alice Blue	221 Blue Frost	278 1/8 Plus Green
169 Lilac Tint	198 Palace Blue	223 1/8 CTO	279 1/8 Minus Green
170 Deep Lavender	199 Regal Blue	224 Daylight Blue Fr	281 3/4 CTB
174 Dark Steel Blue	200 Double CTB	230 L.C.T. Yellow	283 1 1/2 CTB
176 Loving Amber	201 Full CTB	232 W.F. Green	285 3/4 CTO
180 Dark Lavender	202 1/2 CTB	236 HMI to Tungsten	286 1 1/2 CTO
182 Light Red	203 1/4 CTB	237 CID to Tungsten	287 Double CTO
184 Cosmetic Peach	204 Full CTO	238 CSI to Tungsten	441 Full CTS
186 Cosm.Silver Rose	205 1/2 CTO	241 L. Fluoresc.5700K	442 1/2 CTS
187 Cosmetic Rouge	206 1/4 CTO	242 L.Fluoresc.4300K	443 1/4 CTS

"L" GEL LIST (Page 03/03)

444 1/8 CTS	708 Cool Lavender	708 Cool Lavender	776 Nectarine
600 Arctic White	709 Electric Lilac	731 Dirty Ice	778 Millennium Gold
601 Silver	710 Spir Special Blu	733 Damp Squib	779 Bastard Pink
602 Platinum	711 Cold Blue	738 JAS Green	781 Terry Red
603 Moonlight White	712 Bedford Blue	742 Bram Brown	789 Blood Red
604 Full CT 85	714 Elysian Blue	744 Dirty White	790 Moroccan Pink
650 Industry Sodium	715 Cabana Blue	746 Brown	791 Moroccan Frost
651 HI Sodium	716 Mikkell Blue	747 Easy White	794 Pretty n Pink
652 Urban Sodium	717 Shanklin Frost	748 Seedy Pink	795 Magical Magenta
653 LO Sodium	718 Half Shanklin Fr	749 Hampshire Rose	
700 Perfect Lavender	719 Colour Wash Blue	750 Durham Frost	
701 Provence	720 Durham Daylight	763 Wheat	
702 Spec.Pale Lavend	721 Berry Blue	764 Sun Colour Straw	
703 Cold Lavender	723 Virgin Blue	765 L. Yellow	
704 Lily	724 Ocean Blue	773 Cardbox Amber	
705 Lily Frost	725 Old Steel Blue	774 Soft Amber Key 1	
706 King Fals Lavend	728 Steel Green	775 Soft Amber Key 2	

"R" GEL LIST (Page 01/02)

002 Bastard Amber	051 Surprise Pink	318 Mayan Sun	2006 VS Azure
006 No Color Straw	060 No Color Blue	321 Soft Golden Amb.	2007 VS Blue
008 Pale Gold	062 Booster Blue	325 Henna Sky	2008 VS Indigo
012 Straw	065 Daylight Blue	333 Blush Pink	2009 VS Violet
016 Light Amber	077 Green Blue	360 Clearwater	2010 VS Magenta
017 Light Flame	080 Primary Blue	362 Tipton Blue	3102 Tough MT2
018 Flame	083 Medium Blue	364 Blue Bell	3102 Tough MT2
021 Golden Amber	087 Pale Yellow Grn.	365 Tharon Delft Blu	3107 Tough Y-1
023 Orange	088 Light Green	376 Bermuda Blue	3150 Industrial Vapor
026 Light Red	089 Moss Green	376 Bermuda Blue	3150 Industrial Vapor
033 No Color Pink	091 Primary Green	378 Alice Blue	3152 Urban Vapor
034 Flesh Pink	092 Turquoise	381 Baldassari Blue	3202 Full CTB
037 Pale Rose Pink	093 Blue Green	2001 VS Red	3203 3/4 CTB
041 Salmon	099 Chocolate	2002 VS Orange	3204 1/2 CTB
042 Deep Salmon	302 Pale Bastard Amb	2003 VS Yellow	3206 1/3 CTB
044 Middle Rose	310 Daffodil	2004 VS Green	3208 1/4 CTB
047 Light Rose Purp.	316 Gallo Gold	2005 VS Cyan	3216 1/8 CTB

"R" GEL LIST (Page 02/02)

 3220 Double CTB	 3441 Full CTS	 4515 15 Yellow	 4930 30 Lavender
 3304 Full Plusgreen	 3442 1/2 CTS	 4530 30 Yellow	 4960 60 Lavender
 3308 Full Minusgreen	 3443 1/4 CTS	 4560 60 Yellow	 4990 90 Lavender
 3309 3/4 Minusgreen	 3444 1/8 CTS	 4590 90 Yellow	
 3310 Fluorofilter	 4215 15 Blue	 4615 15 Red	
 3313 1/2 Minusgreen	 4230 30 Blue	 4630 30 Red	
 3314 1/4 Minusgreen	 4260 60 Blue	 4660 60 Red	
 3315 1/2 Plusgreen	 4290 90 Blue	 4690 90 Red	
 3316 1/4 Plusgreen	 4307 7 Cyan	 4715 15 Magenta	
 3317 1/8 Plusgreen	 4315 15 Cyan	 4730 30 Magenta	
 3318 1/8 Minusgreen	 4330 30 Cyan	 4760 60 Magenta	
 3407 Full CTO	 4360 60 Cyan	 4790 90 Magenta	
 3408 1/2 CTO	 4390 90 Cyan	 4815 15 Pink	
 3409 1/4 CTO	 4415 15 Green	 4830 30 Pink	
 3410 1/8 CTO	 4430 30 Green	 4860 60 Pink	
 3411 3/4 CTO	 4460 60 Green	 4890 90 Pink	
 3420 Double CTO	 4490 90 Green	 4915 15 Lavender	

PRESETS

KOSMOS allows you to save any white light or color setting of any Working Mode, including the Zoom parameter. A total of ten User Presets can be saved. Each Preset is displayed showing its numerical values of RGB, Color Mode and also its actual color.

1. Press the *PRESET* button from any color mode edit screen.
2. Choose the preset slot you wish to save or load using any of the rotary encoders. Press the encoder button to select.
3. Confirm the preset save or load using the touch display.

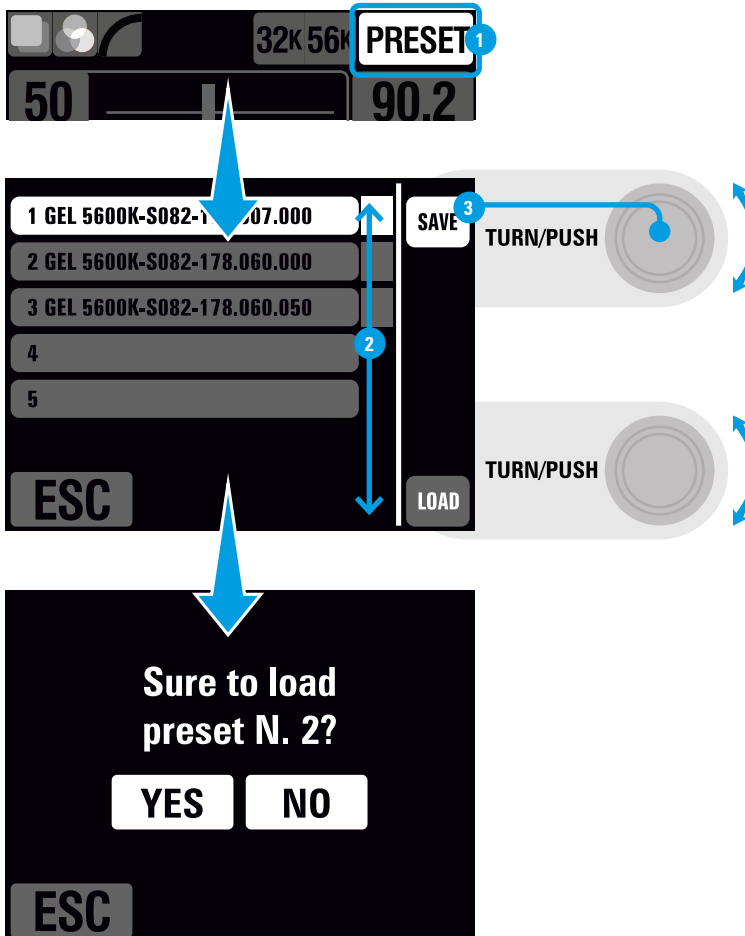

EFFECTOS

KOSMOS allows you to customize any effect by adjusting various parameters. For any effect, you can always use your custom setting or revert to the default values. You can save or load your own effects.

To select different effects:

1. Press the *FX* button from any screen.
2. Click on the effect title box. The box will be highlighted.
3. Select the desired effect using the lower rotary encoder. Press the encoder button to select.
4. Once selected, the customizable parameters of each effect are highlighted. Use the lower encoder knob to select the desired parameter. Press again to modify the value of each parameter and adjust by turning the lower encoder.
5. Press the *RUN* button to start the effect and the *STOP* button to stop.

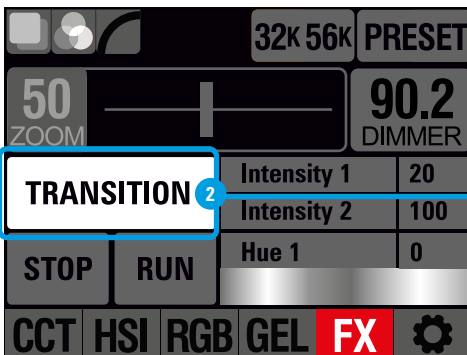
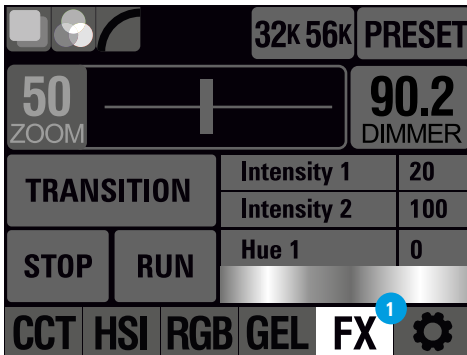

TURN/PUSH

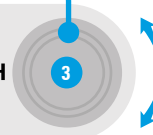

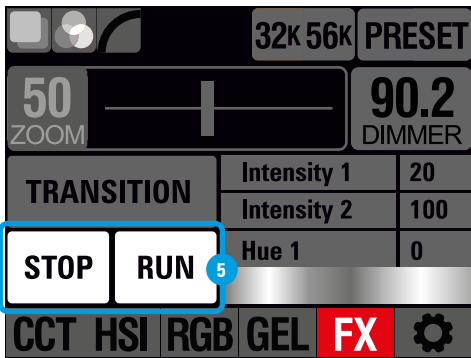
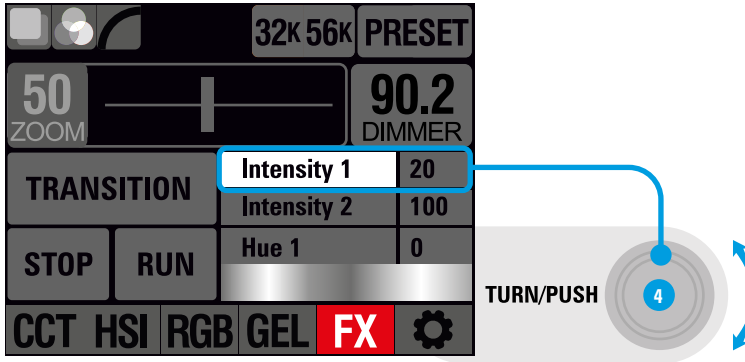

NOTE

The numerical values of the *HUE* parameters range from 0 to 360. Each value corresponds to the degrees of the Munsell color circle.

By adjusting the *HUE 1* and *HUE 2* values it is possible to select the range of colors between which the effect will move.

For effects with *HUE 1* and *HUE 2* parameters the user can see a simulation of the selected tonal range in the preview space.

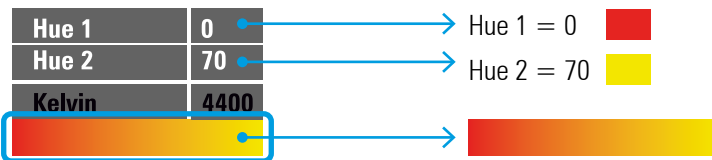

EFFECTS LIST

DISCO

Switches between different colors and intensities, creating a loop. You can select on which colors you want to loop, the smoothness of the transitions, the speed of the changes, etc.

Customizable parameters:

Loop speed / Saturation / Hue 1 (0-360) / Hue 2 (0-360) / Kelvin (2500-9900K) / Smoothness / Direction / Zoom start / Zoom end / Zoom speed

FLAME

A flickering light with adjustment of Color, Saturation, Softness between transitions. You can adjust it to create new personal effects, from a faint candle to a powerful fire or even a water effect by modifying the Hue values on which to create the loop.

Customizable parameters:

Flickr speed / Saturation / Hue 1 (0-360) / Kelvin 2 (2500-9900K) / Smoothness / Zoom start / Zoom end / Zoom speed

POLICE

Flashes of red, blue or any selected combination. From an ambulance or fire truck, to any combination according to the desired effect. You can modify speed, flash duration.

Customizable parameters:

Loop speed / Saturation / Hue 1 (0-360) / Hue 2 (0-360) / Kelvin 3 (2500-9900K) / Kelvin on-off / Smoothness / Direction / Zoom start / Zoom end / Zoom speed

PULSE

Light pulse effect with soft fade in and fade out.

Customizable parameters:

Loop speed / Flash time / Fade out / Saturation / Hue 1 (0-360) / Kelvin 2 (2500-9900K) / Zoom start / Zoom end / Zoom speed

STROBE

White light or color strobe effect.

Customizable parameters:

Saturation / Hue 1 (0-360) / Kelvin 2 (2500-9900K) / Flash time / Zoom start / Zoom end / Zoom speed



Riesgo de lesiones o muerte debido a un colapso epiléptico.
Warn people nearby of the use of a strobe light effect.

TV Emulates a TV screen effect by switching between different white or colored lights, selecting the range of colors displayed and being able to select the smoothness of the transitions and the speed of the loop with varying intensity.

Customizable parameters:

Loop speed / Saturation / Hue 1 (0-360) / Hue 2 (0-360) / Kelvin (2500-9900K) / Smoothness / Direction / Zoom start / Zoom end / Zoom speed

PAPARAZZI Simulates a group of photographic flashes, with different intensities.

Customizable parameters:

Kelvin (2500-9900K) / Flickr speed / Flash time / Zoom start / Zoom end / Zoom speed

SUNRISE Simulates a sunrise.

Customizable parameters:

Intensity 1 / Intensity 2 / Saturation 1 / Saturation 2 / Hue 1 (0-360) / Hue 2 (0-360) / Kelvin 3 (2500-9900K) / Time (sec) / Zoom start / Zoom end / Zoom speed

TRANSITION With this effect you can control a group of luminaires that recreate the effect of a light passing through a moving vehicle.

You can select the number of fixtures that will recreate the effect, the width of the effect, its speed, intensity and tone.

Customizable parameters:

Intensity 1 / Intensity 2 / Hue 1 (0-360) / Hue 2 (0-360) / Time (sec) / Zoom start / Zoom end / Zoom speed

Settings

CONTROL DMX-RDM

KOSMOS offers 10 DMX control Modes on 8 bit and 10 more on 16 bit.

Use the 8-bit modes with basic controllers like dimmer consoles. The DMX mode can be selected on the KOSMOS settings menu.

The control mode named "Changing mode" allow to dynamically and remotely change the DMX mode through a DMX console by changing the channel 2 value on 8-bit or channel 3 value on 16-bit. Please refer to "DMX Map chart 8-bit" and "DMX Chart 16-bit".

The 16 bit Mode use two channels for the intensity parameter and provide higher resolution compared to the 8 bit Mode

DMX ADDRESS

To set the DMX Address push  and then push to *DMX* button.

To set the DMX Address directly set it by rotating the top control knob.

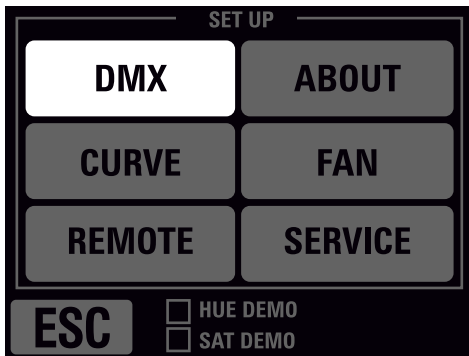

DMX MODE

KOSMOS offers a choice of different DMX modes on 8 bit and on 16 bit.

To set the DMX Mode push  and then push the *DMX* button. Then you can select the DMX mode rotating the bottom control knob. The screen will show you the DMX Map channels according to the selected DMX mode.

DMX LOSS BEHAVIOUR (Comportamiento ante pérdida de señal DMX)

To set the behavior of the fixture when the DMX control signal is lost push  and then push the *DMX* button. Now you can directly tap on the preferred lost behavior option:

Last command: The last received DMX command is used until the fixture is switched off or a valid DMX data is received

Go to local: The fixture goes to the last settings entered in Local.



DMX STATUS: MASTER/ESCLAVO

To select DMX-RDM Status (Master/Slave) push , select *DMX* and then select *MASTER* o *SLAVE*.

Slave setting is set as default. Every time the KOSMOS is powered off the DMX status will be reset to Slave mode.

8 bits DMX MAP CHART (Firmware V01_05)

KOSMOS DMX MAP 8 bits (Firmware V01_05)					
Mode Number	Mode Name	Channel	Function	Value	Kosmos range
1	CCT (5 channels)	1	Master intensity	0-255	0-100
		2	Kelvin	0-255	2500K to 10000K
		3	Green / Magenta	0=Neutral 1-121 = 100M to 1 M 122-132 = Neutral zone 133-255 = 1G to 100G	100M to 100G
		4	ZOOM	0-255	13°-56°
		5	FAN	0-9 = Silence	Fan speed according to LED temperature. Maximum power priority.
				10-19 = Dynamic	Fan speed according to LED temperature. Maximum power priority.
				20-29 = Full Speed	Fan operates at maximum power.
				>=30 = Dynamic	Fan speed according to LED temperature. Maximum power priority.
2	CCT & HSI (7 channels)	1	Master intensity	0-255	0-100
		2	Kelvin	0-255	2500K to 10000K
		3	Green / Magenta	0=Neutral 1-121 = 100M to 1 M 122-132 = Neutral zone 133-255 = 1G to 100G	100M to 100G
		4	Saturation	0-255	0-100
		5	Hue	0-255	0° to 359°
		6	ZOOM	0-255	13°-56°
		7	FAN	0-9 = Silence	Fan speed according to LED temperature. Maximum power priority.
				10-19 = Dynamic	Fan speed according to LED temperature. Maximum power priority.
20-29 = Full Speed	Fan operates at maximum power.				
>=30 = Dynamic	Fan speed according to LED temperature. Maximum power priority.				
3	CCT & RGB (9 channels)	1	Master intensity	0-255	0-100
		2	Kelvin	0-255	2500K to 10000K
		3	Green / Magenta	0=Neutral 1-121 = 100M to 1 M 122-132 = Neutral zone 133-255 = 1G to 100G	100M to 100G
		4	Saturation	0-255	0-100
		5	Red	0-255	0-100
		6	Green	0-255	0-100
		7	Blue	0-255	0-100
		8	ZOOM	0-255	13°-56°
		9	FAN	0-9 = Silence	Fan speed according to LED temperature. Maximum power priority.
10-19 = Dynamic	Fan speed according to LED temperature. Maximum power priority.				
20-29 = Full Speed	Fan operates at maximum power.				
>=30 = Dynamic	Fan speed according to LED temperature. Maximum power priority.				

4	RGBWW (8 channels)	1	Master intensity	0-255	0-100
		2	Red	0-255	0-100
		3	Green	0-255	0-100
		4	Blue	0-255	0-100
		5	Cold White	0-255	0-100
		6	White	0-255	0-100
		7	ZOOM	0-255	13°-56°
		8	FAN	0-9 = Silence 10-19 = Dynamic 20-29 = Full Speed > =30 = Dynamic	Fan speed according to LED temperature. Maximum power priority. Fan speed according to LED temperature. Maximum power priority. Fan operates at maximum power. Fan speed according to LED temperature. Maximum power priority.
5	GELS (7 channels)	1	Master intensity	0-255	0-100
		2	Kelvin	0-255	2500K to 10000K
		3	Saturation	0-255	0-100
		4	Gel family	0=L 1=R	See document L GEL list See document R GEL list
		5	Gel number	0-255	
		6	ZOOM	0-255	13°-56°
		7	FAN	0-9 = Silence 10-19 = Dynamic 20-29 = Full Speed > =30 = Dynamic	Fan speed according to LED temperature. Maximum power priority. Fan speed according to LED temperature. Maximum power priority. Fan operates at maximum power. Fan speed according to LED temperature. Maximum power priority.
6	LIGHT SOURCES (6 channels)	1	Master intensity	0-255	0-100
		2	Kelvin	0-255	2500K to 10000K
		3	Saturation	0-255	0-100
		4	Light Source number	0-255	See document Lightsources list
		5	ZOOM	0-255	13°-56°
		6	FAN	0-9 = Silence 10-19 = Dynamic 20-29 = Full Speed > =30 = Dynamic	Fan speed according to LED temperature. Maximum power priority. Fan speed according to LED temperature. Maximum power priority. Fan operates at maximum power. Fan speed according to LED temperature. Maximum power priority.
7	PRESETS (3 channels)	1	Master intensity	0-255	0-100
		2	Preset number	0-255	0-10
		3	FAN	0-9 = Silence 10-19 = Dynamic 20-29 = Full Speed > =30 = Dynamic	Fan speed according to LED temperature. Maximum power priority. Fan speed according to LED temperature. Maximum power priority. Fan operates at maximum power. Fan speed according to LED temperature. Maximum power priority.
8	EFFECTS (14 channels)	1	Master intensity	0-255	0-100
		2	Effect number	0-255	See document FX MODE PARAMETERS 8 BIT
		3	Parameter #1	0-255	0-100
		4	Parameter #2	0-255	0-100
		5	Parameter #3	0-255	0-100

		6	Parameter #4	0-255	0-100
		7	Parameter #5	0-255	0-100
		8	Parameter #6	0-255	0-100
		9	Parameter #7	0-255	0-100
		10	Parameter #8	0-255	0-100
		11	ZOOM START Position	0-255	13°-56°
		12	ZOOM STOP Position	0-255	13°-56°
		13	ZOOM SPEED	0-255	0-100
		14	FAN	0-9 = Silence	Fan speed according to LED temperature. Maximum power priority.
				10-19 = Dynamic	Fan speed according to LED temperature. Maximum power priority.
				20-29 = Full Speed	Fan operates at maximum power.
				>=30 = Dynamic	Fan speed according to LED temperature. Maximum power priority.
9	CHANGING Mode CCT (6 channels)	1	Master intensity	0-255	0-100
		2	Mode 0-9 : CCT	0-9	CCT
		3	Kelvin	0-255	2500K to 10000K
		4	Green / Magenta	0=Neutral 1-121= 100M to 1 M 122-132= Neutral zone 133-255 = 1G to 100G	100M to 100G
		5	ZOOM	0-255	13°-56°
		6	FAN	0-9 = Silence	Fan speed according to LED temperature. Maximum power priority.
				10-19 = Dynamic	Fan speed according to LED temperature. Maximum power priority.
				20-29 = Full Speed	Fan operates at maximum power.
				>=30 = Dynamic	Fan speed according to LED temperature. Maximum power priority.
	CHANGING Mode CCT+HSI (8 channels)	1	Master intensity	0-255	0-100
		2	Mode 10-19 : CCT+HSI	10-19	CCT+HSI
		3	Kelvin	0-255	2500K to 10000K
		4	Green / Magenta	0=Neutral 1-121= 100M to 1 M 122-132= Neutral zone 133-255 = 1G to 100G	100M to 100G
		5	Saturation	0-255	0-100
		6	Hue	0-255	0° to 359°
		7	ZOOM	0-255	13°-56°
		8	FAN	0-9 = Silence	Fan speed according to LED temperature. Maximum power priority.
				10-19 = Dynamic	Fan speed according to LED temperature. Maximum power priority.
				20-29 = Full Speed	Fan operates at maximum power.
				>=30 = Dynamic	Fan speed according to LED temperature. Maximum power priority.
	CHANGING Mode CCT+RGB (10 channels)	1	Master intensity	0-255	0-100
		2	Mode 20-29 : CCT+RGB	20-29	CCT+RGB
		3	Kelvin	0-255	2500K to 10000K
		4	Green / Magenta	0=Neutral 1-121= 100M to 1 M 122-132= Neutral zone 133-255 = 1G to 100G	100M to 100G
		5	Saturation	0-255	0-100
		6	Red	0-255	0-100

	7	Green	0-255	0-100	
	8	Blue	0-255	0-100	
	9	ZOOM	0-255	13°-56°	
	10	FAN	0-9 = Silence	Fan speed according to LED temperature. Maximum power priority.	
			10-19 = Dynamic	Fan speed according to LED temperature. Maximum power priority.	
			20-29 = Full Speed	Fan operates at maximum power.	
			> =30 = Dynamic	Fan speed according to LED temperature. Maximum power priority.	
CHANGING Mode RGBWW (9 channels)	1	Master intensity	0-255	0-100	
	2	Mode 30-39 : RGBWW	30-39	RGBWW	
	3	Red	0-255	0-100	
	4	Green	0-255	0-100	
	5	Blue	0-255	0-100	
	6	Cold White %	0-255	0-100	
	7	White %	0-255	0-100	
	8	ZOOM	0-255	13°-56°	
		9	FAN	0-9 = Silence	Fan speed according to LED temperature. Maximum power priority.
	10-19 = Dynamic			Fan speed according to LED temperature. Maximum power priority.	
	20-29 = Full Speed			Fan operates at maximum power.	
	> =30 = Dynamic			Fan speed according to LED temperature. Maximum power priority.	
CHANGING Mode GEL (8 channels)	1	Master intensity	0-255	0-100	
	2	Mode 40-49 : GEL	40-49	GEL	
	3	Kelvin	0-255	2500K to 10000K	
	4	Saturation	0-255	0-100	
	5	Gel family	0=L 1=R	See document L GEL list See document R GEL list	
	6	Gel number	0-255	0-100	
	7	ZOOM	0-255	13°-56°	
		8	FAN	0-9 = Silence	Fan speed according to LED temperature. Maximum power priority.
				10-19 = Dynamic	Fan speed according to LED temperature. Maximum power priority.
	20-29 = Full Speed			Fan operates at maximum power.	
	> =30 = Dynamic			Fan speed according to LED temperature. Maximum power priority.	
CHANGING Mode LIGHT SOURCES (7 channels)	1	Master intensity	0-255	0-100	
	2	Mode 50-59 : LIGHT SOURCES	50-59	LIGHT SOURCES	
	3	Kelvin	0-255	2500K to 10000K	
	4	Saturation	0-255	0-100	
	5	Lightsources number	0-255	See document Lightsources list	
	6	ZOOM	0-255	13°-56°	
		7	FAN	0-9 = Silence	Fan speed according to LED temperature. Maximum power priority.
				10-19 = Dynamic	Fan speed according to LED temperature. Maximum power priority.
	20-29 = Full Speed			Fan operates at maximum power.	
	> =30 = Dynamic			Fan speed according to LED temperature. Maximum power priority.	

	CHANGING Mode PRESETS (4 channels)	1	Master intensity	0-255	0-100
		2	Mode 60-69 : PRESETS	60-69	PRESETS
		3	Preset number	0-255	0-10
		4	FAN	0-9 = Silence	Fan speed according to LED temperature. Maximum power priority.
				10-19 = Dynamic	Fan speed according to LED temperature. Maximum power priority.
	20-29 = Full Speed			Fan operates at maximum power.	
	> =30 = Dynamic			Fan speed according to LED temperature. Maximum power priority.	
	CHANGING Mode EFFECTS (15 channels)	1	Master intensity	0-255	0-100
		2	Mode 70-79 : EFFECTS	70-79	EFFECTS
		3	Effect number	0-255	See document FX MODE PARAMETERS 8 BIT
		4	Parameter #1	0-255	0-100
		5	Parameter #2	0-255	0-100
		6	Parameter #3	0-255	0-100
		7	Parameter #4	0-255	0-100
		8	Parameter #5	0-255	0-100
9		Parameter #6	0-255	0-100	
10		Parameter #7	0-255	0-100	
11		Parameter #8	0-255	0-100	
12		ZOOM START Position	0-255	13°-56°	
13		ZOOM STOP Position	0-255	13°-56°	
14		ZOOM SPEED	0-255	0-100	
15		FAN	0-9 = Silence	Fan speed according to LED temperature. Maximum power priority.	
	10-19 = Dynamic		Fan speed according to LED temperature. Maximum power priority.		
	20-29 = Full Speed		Fan operates at maximum power.		
	> =30 = Dynamic		Fan speed according to LED temperature. Maximum power priority.		
10	FULL Mode (138 channels)	1	Master intensity	0-255	0-100
		2		0-9	BASE COLOR RGBWW GELS LIGHTSOURCES PRESETS Effect 1 DISCO Effect 2 FLAME Effect 3 POLICE Effect 4 PULSE Effect 5 STROBE Effect 6 TV Effect 7 PAPAZZI Effect 8 SUNRISE Effect 9 TRANSITION
				10-19	
				20-29	
				30-39	
				40-49	
				50-59	
				60-69	
				70-79	
80-89					
90-99					
100-109					
110-119					
120-129					
130-139					
3	Kelvin	0-255	2500K to 10000K		
4	Green / Magenta (100M to 100G)	0 = Neutral 1-121 = 100M to 1 M 122-132 = Neutral zone 1G to 100G	100M to 100G		
5	Saturation	0-255	0-100		
6	Red	0-255	0-100		
7	Green	0-255	0-100		
8	Blue	0-255	0-100		
9	ZOOM	0-255	13°-56°		

10	FAN	0-9 = Silence	Fan speed according to LED temperature. Maximum power priority.
		10-19 = Dynamic	Fan speed according to LED temperature. Maximum power priority.
		20-29 = Full Speed	Fan operates at maximum power.
		> =30 = Dynamic	Fan speed according to LED temperature. Maximum power priority.
11	Red	0-255	0-100
12	Green	0-255	0-100
13	Blue	0-255	0-100
14	Cold White	0-255	0-100
15	White	0-255	0-100
16	ZOOM	0-255	13°-56°
17	FAN	0-9 = Silence	Fan speed according to LED temperature. Maximum power priority.
		10-19 = Dynamic	Fan speed according to LED temperature. Maximum power priority.
		20-29 = Full Speed	Fan operates at maximum power.
		> =30 = Dynamic	Fan speed according to LED temperature. Maximum power priority.
18	Kelvin	0-255	2500K to 10000K
19	Saturation	0-255	0-100
20	Gel family	0=L 1=R	See document L GEL list document R GEL list
21	Gel number	0-255	0-100
22	ZOOM	0-255	13°-56°
23	FAN	0-9 = Silence	Fan speed according to LED temperature. Maximum power priority.
		10-19 = Dynamic	Fan speed according to LED temperature. Maximum power priority.
		20-29 = Full Speed	Fan operates at maximum power.
		> =30 = Dynamic	Fan speed according to LED temperature. Maximum power priority.
24	Kelvin	0-255	2500K to 10000K
25	Saturation	0-255	0-100
26	Light Source number	0-255	See document Lightsources list
27	ZOOM	0-255	13°-56°
28	FAN	0-9 = Silence	Fan speed according to LED temperature. Maximum power priority.
		10-19 = Dynamic	Fan speed according to LED temperature. Maximum power priority.
		20-29 = Full Speed	Fan operates at maximum power.
		> =30 = Dynamic	Fan speed according to LED temperature. Maximum power priority.
29	Preset number	0-255	0-10
30	FAN	0-9 = Silence	Fan speed according to LED temperature. Maximum power priority.
		10-19 = Dynamic	Fan speed according to LED temperature. Maximum power priority.
		20-29 = Full Speed	Fan operates at maximum power.
		> =30 = Dynamic	Fan speed according to LED temperature. Maximum power priority.
31	DISCO Loop speed	0-255	0-100
32	DISCO Saturation	0-255	0-100

33	DISCO Hue 1	0-255	0° to 359°
34	DISCO Hue 2	0-255	0° to 359°
35	DISCO Kelvin	0-255	2500K to 10000K
36	DISCO Smoothness	0-255	0-100
37	DISCO Direction	0-255	0-100
38	Parameter #8	0-255	0-100
39	ZOOM START Position	0-255	13°-56°
40	ZOOM STOP Position	0-255	13°-56°
41	ZOOM SPEED	0-255	0-100
42	FAN	0-9 = Silence	Fan speed according to LED temperature. Maximum power priority.
		10-19 = Dynamic	Fan speed according to LED temperature. Maximum power priority.
		20-29 = Full Speed	Fan operates at maximum power.
		> =30 = Dynamic	Fan speed according to LED temperature. Maximum power priority.
43	FLAME Flicker speed	0-255	0-100
44	FLAME Saturation	0-255	0-100
45	FLAME Hue	0-255	0° to 359°
46	FLAME Kelvin	0-255	2500K to 10000K
47	FLAME Smoothness	0-255	0-100
48	Parameter #6	0-255	0-100
49	Parameter #7	0-255	0-100
50	Parameter #8	0-255	0-100
51	ZOOM START Position	0-255	13°-56°
52	ZOOM STOP Position	0-255	13°-56°
53	ZOOM SPEED	0-255	0-100
54	FAN	0-9 = Silence	Fan speed according to LED temperature. Maximum power priority.
		10-19 = Dynamic	Fan speed according to LED temperature. Maximum power priority.
		20-29 = Full Speed	Fan operates at maximum power.
		> =30 = Dynamic	Fan speed according to LED temperature. Maximum power priority.
55	POLICE Loop speed	0-255	0-100
56	POLICE Saturation	0-255	0-100
57	POLICE Hue 1	0-255	0° to 359°
58	POLICE Hue 2	0-255	0° to 359°
59	POLICE Kelvin	0-255	2500K to 10000K
60	POLICE Smoothness	0-255	0-100
61	Parameter #7	0-255	0-100
62	Parameter #8	0-255	0-100
63	ZOOM START Position	0-255	13°-56°
64	ZOOM STOP Position	0-255	13°-56°
65	ZOOM SPEED	0-255	0-100
66	FAN	0-9 = Silence	Fan speed according to LED temperature. Maximum power priority.
		10-19 = Dynamic	Fan speed according to LED temperature. Maximum power priority.
		20-29 = Full Speed	Fan operates at maximum power.
		> =30 = Dynamic	Fan speed according to LED temperature. Maximum power priority.
67	PULSE Loop speed	0-255	0-100

68	PULSE Flash time	0-255	0-100
69	PULSE Fade out	0-255	0-100
70	PULSE Saturation	0-255	0-100
71	PULSE Hue	0-255	0° to 359°
72	PULSE Kelvin	0-255	2500K to 10000K
73	Parameter #7	0-255	0-100
74	Parameter #8	0-255	0-100
75	ZOOM START Position	0-255	13°-56°
76	ZOOM STOP Position	0-255	13°-56°
77	ZOOM SPEED	0-255	0-100
78	FAN	0-9 = Silence	Fan speed according to LED temperature. Maximum power priority.
		10-19 = Dynamic	Fan speed according to LED temperature. Maximum power priority.
		20-29 = Full Speed	Fan operates at maximum power.
		> =30 = Dynamic	Fan speed according to LED temperature. Maximum power priority.
79	STROBE Saturation	0-255	0-100
80	STROBE Hue	0-255	0° to 359°
81	STROBE Kelvin	0-255	2500K to 10000K
82	STROBE Flash time	0-255	0-100
83	Parameter #5	0-255	0-100
84	Parameter #6	0-255	0-100
85	Parameter #7	0-255	0-100
86	Parameter #8	0-255	0-100
87	ZOOM START Position	0-255	13°-56°
88	ZOOM STOP Position	0-255	13°-56°
89	ZOOM SPEED	0-255	0-100
90	FAN	0-9 = Silence	Fan speed according to LED temperature. Maximum power priority.
		10-19 = Dynamic	Fan speed according to LED temperature. Maximum power priority.
		20-29 = Full Speed	Fan operates at maximum power.
		> =30 = Dynamic	Fan speed according to LED temperature. Maximum power priority.
91	TV Loop speed	0-255	0-100
92	TV Saturation	0-255	0-100
93	TV Hue 1	0-255	0° to 359°
94	TV Hue 2	0-255	0° to 359°
95	TV Smoothness	0-255	0-100
96	TV Direction	0-255	0-100
97	Parameter #7	0-255	0-100
98	Parameter #8	0-255	0-100
99	ZOOM START Position	0-255	13°-56°
100	ZOOM STOP Position	0-255	13°-56°
101	ZOOM SPEED	0-255	0-100
102	FAN	0-9 = Silence	Fan speed according to LED temperature. Maximum power priority.
		10-19 = Dynamic	Fan speed according to LED temperature. Maximum power priority.
		20-29 = Full Speed	Fan operates at maximum power.
		> =30 = Dynamic	Fan speed according to LED temperature. Maximum power priority.

103	PAPARAZZI Kelvin	0-255	2500K to 10000K
104	PAPARAZZI Flicker speed	0-255	0-100
105	PAPARAZZI Flash time	0-255	0-100
106	Parameter #4	0-255	0-100
107	Parameter #5	0-255	0-100
108	Parameter #6	0-255	0-100
109	Parameter #7	0-255	0-100
110	Parameter #8	0-255	0-100
111	ZOOM START Position	0-255	13°-56°
112	ZOOM STOP Position	0-255	13°-56°
113	ZOOM SPEED	0-255	0-100
114	FAN	0-9 = Silence	Fan speed according to LED temperature. Maximum power priority.
		10-19 = Dynamic	Fan speed according to LED temperature. Maximum power priority.
		20-29 = Full Speed	Fan operates at maximum power.
		> =30 = Dynamic	Fan speed according to LED temperature. Maximum power priority.
115	SUNRISE Intensity 1	0-255	0-100
116	SUNRISE Intensity 2	0-255	0-100
117	SUNRISE Saturation 1	0-255	0-100
118	SUNRISE Saturation 2	0-255	0-100
119	SUNRISE Hue 1	0-255	0° to 359°
120	SUNRISE Hue 2	0-255	0° to 359°
121	SUNRISE Kelvin	0-255	2500K to 10000K
122	SUNRISE Time	0-255	0-100
123	ZOOM START Position	0-255	13°-56°
124	ZOOM STOP Position	0-255	13°-56°
125	ZOOM SPEED	0-255	0-100
126	FAN	0-9 = Silence	Fan speed according to LED temperature. Maximum power priority.
		10-19 = Dynamic	Fan speed according to LED temperature. Maximum power priority.
		20-29 = Full Speed	Fan operates at maximum power.
		> =30 = Dynamic	Fan speed according to LED temperature. Maximum power priority.
127	TRANSITION Light intensity 1	0-255	0-100
128	TRANSITION Light intensity 2	0-255	0-100
129	TRANSITION Hue 1	0-255	0° to 359°
130	TRANSITION Hue 2	0-255	0° to 359°
131	TRANSITION Time	0-255	0-100
132	Parameter #6	0-255	0-100
133	Parameter #7	0-255	0-100
134	Parameter #8	0-255	0-100
135	ZOOM START Position	0-255	13°-56°
136	ZOOM STOP Position	0-255	13°-56°
137	ZOOM SPEED	0-255	0-100
138	FAN	0-9 = Silence	Fan speed according to LED temperature. Maximum power priority.
		10-19 = Dynamic	Fan speed according to LED temperature. Maximum power priority.
		20-29 = Full Speed	Fan operates at maximum power.
		> =30 = Dynamic	Fan speed according to LED temperature. Maximum power priority.

16 bits DMX MAP CHART (Firmware V01_05)

KOSMOS DMX MAP 16 bits (Firmware V01_05)					
Mode Number	Mode Name	Channel	Function	Value	Kosmos range
1	CCT (6 channels)	1	Master intensity Course	0-255	0-65535
		2	Master intensity Fine	0-255	0-100
		3	Kelvin	0-255	2500K to 10000K
		4	Green / Magenta	0 = Neutral 1-121 = 100M to 1 M 122-132 = Neutral zone 133-255 = 1G to 100G	100M to 100G
		5	ZOOM	0-255	13°-56°
		6	FAN	0-9 = Silence	Fan speed according to LED temperature. Maximum power priority.
				10-19 = Dynamic	Fan speed according to LED temperature. Maximum power priority.
				20-29 = Full Speed	Fan operates at maximum power.
				> =30 = Dynamic	Fan speed according to LED temperature. Maximum power priority.
		2	CCT & HSI (8 channels)	1	Master intensity
2	Master intensity Fine			0-255	0-100
3	Kelvin			0-255	2500K to 10000K
4	Green / Magenta			0 = Neutral 1-121 = 100M to 1 M 122-132 = Neutral zone 133-255 = 1G to 100G	100M to 100G
5	Saturation			0-255	0-100
6	Hue			0-255	0° to 359°
7	ZOOM			0-255	13°-56°
8	FAN			0-9 = Silence	Fan speed according to LED temperature. Maximum power priority.
				10-19 = Dynamic	Fan speed according to LED temperature. Maximum power priority.
				20-29 = Full Speed	Fan operates at maximum power.
		> =30 = Dynamic	Fan speed according to LED temperature. Maximum power priority.		
3	CCT & RGB (13 channels)	1	Master intensity	0-255	0-65535
		2	Master intensity Fine	0-255	0-100
		3	Kelvin	0-255	2500K to 10000K
		4	Green / Magenta	0 = Neutral 1-121 = 100M to 1 M 122-132 = Neutral zone 133-255 = 1G to 100G	100M to 100G
		5	Saturation	0-255	0-100
		6	Red	0-255	0-65535
		7	Red Fine	0-255	0-100
		8	Green	0-255	0-65535
		9	Green Fine	0-255	0-100
		10	Blue	0-255	0-65535
		11	Blue Fine	0-255	0-100
		12	ZOOM	0-255	13°-56°

		13	FAN	0-9 = Silence	Fan speed according to LED temperature. Maximum power priority.
				10-19 = Dynamic	Fan speed according to LED temperature. Maximum power priority.
				20-29 = Full Speed	Fan operates at maximum power.
				> =30 = Dynamic	Fan speed according to LED temperature. Maximum power priority.
4	RGBWW (14 channels)	1	Master intensity	0-255	0-65535
		2	Master intensity Fine	0-255	0-100
		3	Red	0-255	0-65535
		4	Red Fine	0-255	0-100
		5	Green	0-255	0-65535
		6	Green Fine	0-255	0-100
		7	Blue	0-255	0-65535
		8	Blue Fine	0-255	0-100
		9	Cold White	0-255	0-65535
		10	Cold White Fine	0-255	0-100
		11	White	0-255	0-65535
		12	White Fine	0-255	0-100
		13	ZOOM	0-255	13°-56°
		14	FAN	0-9 = Silence	Fan speed according to LED temperature. Maximum power priority.
		10-19 = Dynamic	Fan speed according to LED temperature. Maximum power priority.		
		20-29 = Full Speed	Fan operates at maximum power.		
		> =30 = Dynamic	Fan speed according to LED temperature. Maximum power priority.		
5	GELS (8 channels)	1	Master intensity	0-255	0-65535
		2	Master intensity Fine	0-255	0-100
		3	Kelvin	0-255	2500K to 10000K
		4	Saturation	0-255	0-100
		5	Gel family	0=L 1=R	See document L GEL list See document R GEL list
		6	Gel number	0-255	
		7	ZOOM	0-255	13°-56°
		8	FAN	0-9 = Silence	Fan speed according to LED temperature. Maximum power priority.
		10-19 = Dynamic	Fan speed according to LED temperature. Maximum power priority.		
		20-29 = Full Speed	Fan operates at maximum power.		
		> =30 = Dynamic	Fan speed according to LED temperature. Maximum power priority.		
6	LIGHT SOURCES (7 channels)	1	Master intensity	0-255	0-65535
		2	Master intensity Fine	0-255	0-100
		3	Kelvin	0-255	2500K to 10000K
		4	Saturation	0-255	0-100
		5	Light Source number	0-255	See document Lightsources list
		6	ZOOM	0-255	13°-56°

		7	FAN	0-9 = Silence	Fan speed according to LED temperature. Maximum power priority.
				10-19 = Dynamic	Fan speed according to LED temperature. Maximum power priority.
				20-29 = Full Speed	Fan operates at maximum power.
				> =30 = Dynamic	Fan speed according to LED temperature. Maximum power priority.
7	PRESETS (4 channels)	1	Master intensity	0-255	0-65535
		2	Master intensity Fine	0-255	0-100
		3	Preset number	0-255	0-10
		4	FAN	0-9 = Silence	Fan speed according to LED temperature. Maximum power priority.
				10-19 = Dynamic	Fan speed according to LED temperature. Maximum power priority.
				20-29 = Full Speed	Fan operates at maximum power.
				> =30 = Dynamic	Fan speed according to LED temperature. Maximum power priority.
8	EFFECTS (15 channels)	1	Master intensity	0-255	0-65535
		2	Master intensity Fine	0-255	0-100
		3	Effect number	0-255	See document FX MODE PARAMETERS 16 BIT
		4	Parameter #1	0-255	0-100
		5	Parameter #2	0-255	0-100
		6	Parameter #3	0-255	0-100
		7	Parameter #4	0-255	0-100
		8	Parameter #5	0-255	0-100
		9	Parameter #6	0-255	0-100
		10	Parameter #7	0-255	0-100
		11	Parameter #8	0-255	0-100
		12	ZOOM START Position	0-255	13°-56°
		13	ZOOM STOP Position	0-255	13°-56°
		14	ZOOM SPEED	0-255	0-100
		15	FAN	0-9 = Silence	Fan speed according to LED temperature. Maximum power priority.
				10-19 = Dynamic	Fan speed according to LED temperature. Maximum power priority.
				20-29 = Full Speed	Fan operates at maximum power.
				> =30 = Dynamic	Fan speed according to LED temperature. Maximum power priority.
9	CHANGING Mode CCT (7 channels)	1	Master intensity	0-255	0-65535
		2	Master intensity Fine	0-255	0-100
		3	Mode 0-9 : CCT	0-9	CCT
		4	Kelvin	0-255	2500K to 10000K
		5	Green / Magenta	0=Neutral 1-121=100M to 1 M 122-132= Neutral zone 133-255 = 1G to 100G	100M to 100G
		6	ZOOM	0-255	13°-56°
		7	FAN	0-9 = Silence	Fan speed according to LED temperature. Maximum power priority.
				10-19 = Dynamic	Fan speed according to LED temperature. Maximum power priority.
				20-29 = Full Speed	Fan operates at maximum power.
				> =30 = Dynamic	Fan speed according to LED temperature. Maximum power priority.

CHANGING Mode CCT+HSI (9 channels)	1	Master intensity	0-255	0-65535
	2	Master intensity Fine	0-255	0-100
	3	Mode 10-19 : CCT+HSI	10-19	CCT+HSI
	4	Kelvin	0-255	2500K to 10000K
	5	Green / Magenta	0=Neutral 1-121=100M to 1 M 122-132= Neutral zone 133-255 = 1G to 100G	100M to 100G
	6	Saturation	0-255	0-100
	7	Hue	0-255	0° to 359°
	8	ZOOM	0-255	13°-56°
	9	FAN	0-9 = Silence 10-19 = Dynamic 20-29 = Full Speed > =30 = Dynamic	Fan speed according to LED temperature. Maximum power priority. Fan speed according to LED temperature. Maximum power priority. Fan operates at maximum power. Fan speed according to LED temperature. Maximum power priority.
CHANGING Mode CCT+RGB (14 channels)	1	Master intensity	0-255	0-65535
	2	Master intensity Fine	0-255	0-100
	3	Mode 20-29 : CCT+RGB	20-29	CCT+RGB
	4	Kelvin	0-255	2500K to 10000K
	5	Green / Magenta	0=Neutral 1-121=100M to 1 M 122-132= Neutral zone 133-255 = 1G to 100G	100M to 100G
	6	Saturation	0-255	0-100
	7	Red	0-255	0-65535
	8	Red Fine	0-255	0-100
	9	Green	0-255	0-65535
	10	Green Fine	0-255	0-100
	11	Blue	0-255	0-65535
	12	Blue Fine	0-255	0-100
	13	ZOOM	0-255	13°-56°
	14	FAN	0-9 = Silence 10-19 = Dynamic 20-29 = Full Speed > =30 = Dynamic	Fan speed according to LED temperature. Maximum power priority. Fan speed according to LED temperature. Maximum power priority. Fan operates at maximum power. Fan speed according to LED temperature. Maximum power priority.
CHANGING Mode RGBWW (15 channels)	1	Master intensity	0-255	0-65535
	2	Master intensity Fine	0-255	0-100
	3	Mode 30-39 : RGBWW	30-39	RGBWW
	4	Red	0-255	0-65535
	5	Red Fine	0-255	0-100
	6	Green	0-255	0-65535
	7	Green Fine	0-255	0-100
	8	Blue	0-255	0-65535
	9	Blue Fine	0-255	0-100
	10	Cold White	0-255	0-65535
	11	Cold White Fine	0-255	0-100
	12	White	0-255	0-65535
	13	White Fine	0-255	0-100

	14	ZOOM	0-255	13°-56°
	15	FAN	0-9 = Silence	Fan speed according to LED temperature. Maximum power priority.
			10-19 = Dynamic	Fan speed according to LED temperature. Maximum power priority.
			20-29 = Full Speed	Fan operates at maximum power.
			> =30 = Dynamic	Fan speed according to LED temperature. Maximum power priority.
CHANGING Mode GEL (9 channels)	1	Master intensity	0-255	0-65535
	2	Master intensity Fine	0-255	0-100
	3	Mode 40-49 : GEL	40-49	GEL
	4	Kelvin	0-255	2500K to 10000K
	5	Saturation	0-255	0-100
	6	Gel family	0=L 1=R	See document L GEL list See document R GEL list
	7	Gel number	0-255	0-100
	8	ZOOM	0-255	13°-56°
		9	FAN	0-9 = Silence
	10-19 = Dynamic			Fan speed according to LED temperature. Maximum power priority.
	20-29 = Full Speed			Fan operates at maximum power.
	> =30 = Dynamic			Fan speed according to LED temperature. Maximum power priority.
CHANGING Mode LIGHT SOURCES (8 channels)	1	Master intensity	0-255	0-65535
	2	Master intensity Fine	0-255	0-100
	3	Mode 50-59 : LIGHT SOURCES	50-59	LIGHT SOURCES
	4	Kelvin	0-255	2500K to 10000K
	5	Saturation	0-255	0-100
	6	Lightsource number	0-255	See document Lightsources list
	7	ZOOM	0-255	13°-56°
		8	FAN	0-9 = Silence
	10-19 = Dynamic			Fan speed according to LED temperature. Maximum power priority.
	20-29 = Full Speed			Fan operates at maximum power.
	> =30 = Dynamic			Fan speed according to LED temperature. Maximum power priority.
CHANGING Mode PRESETS (5 channels)	1	Master intensity	0-255	0-65535
	2	Master intensity Fine	0-255	0-100
	3	Mode 60-69 : PRESETS	60-69	PRESETS
	4	Preset number	0-255	0-10
		5	FAN	0-9 = Silence
	10-19 = Dynamic			Fan speed according to LED temperature. Maximum power priority.
	20-29 = Full Speed			Fan operates at maximum power.
	> =30 = Dynamic			Fan speed according to LED temperature. Maximum power priority.
CHANGING Mode EFFECTS (16 channels)	1	Master intensity	0-255	0-65535
	2	Master intensity Fine	0-255	0-100
	3	Mode 70-79 : EFFECTS	70-79	EFFECTS

		4	Effect number	0-255	See document FX MODE PARAMETERS 8 BIT
		5	Parameter #1	0-255	0-100
		6	Parameter #2	0-255	0-100
		7	Parameter #3	0-255	0-100
		8	Parameter #4	0-255	0-100
		9	Parameter #5	0-255	0-100
		10	Parameter #6	0-255	0-100
		11	Parameter #7	0-255	0-100
		12	Parameter #8	0-255	0-100
		13	ZOOM START Position	0-255	13°-56°
		14	ZOOM STOP Position	0-255	13°-56°
		15	ZOOM SPEED	0-255	0-100
		16	FAN	0-9 = Silence	Fan speed according to LED temperature. Maximum power priority.
				10-19 = Dynamic	Fan speed according to LED temperature. Maximum power priority.
				20-29 = Full Speed	Fan operates at maximum power.
		>=30 = Dynamic	Fan speed according to LED temperature. Maximum power priority.		
10	FULL Mode (138 channels)	1	Master intensity	0-255	0-65535
		2	Master intensity Fine	0-255	0-100
		3	Control selector	0-9 10-19 20-29 30-39 40-49 50-59 60-69 70-79 80-89 90-99 100-109 110-119 120-129 130-139	BASE COLOR RGBWW GELS LIGHTSOURCES PRESETS Effect 1 DISCO Effect 2 FLAME Effect 3 POLICE Effect 4 PULSE Effect 5 STROBE Effect 6 TV Effect 7 PAPARAZZI Effect 8 SUNRISE Effect 9 TRANSITION
		4	Kelvin	0-255	2500K to 10000K
		5	Green / Magenta (100M to 100G)	0=Neutral 1-121=100M to 1 M 122-132= Neutral zone 133-255 = 1G to 100G	100M to 100G
		6	Saturation	0-255	0-100
		7	Red	0-255	0-65535
		8	Red Fine	0-255	0-100
		9	Green	0-255	0-65535
		10	Green Fine	0-255	0-100
		11	Blue	0-255	0-65535
		12	Blue Fine	0-255	0-100
		13	ZOOM	0-255	13°-56°
		14	FAN	0-9 = Silence	Fan speed according to LED temperature. Maximum power priority.
				10-19 = Dynamic	Fan speed according to LED temperature. Maximum power priority.
		20-29 = Full Speed	Fan operates at maximum power.		
		>=30 = Dynamic	Fan speed according to LED temperature. Maximum power priority.		
15	Red	0-255	0-65535		

16	Red Fine	0-255	0-100
17	Green	0-255	0-65535
18	Green Fine	0-255	0-100
19	Blue	0-255	0-65535
20	Blue Fine	0-255	0-100
21	Cold White	0-255	0-65535
22	Cold White Fine	0-255	0-100
23	White	0-255	0-65535
24	White Fine	0-255	0-100
25	ZOOM	0-255	13°-56°
26	FAN	0-9 = Silence	Fan speed according to LED temperature. Maximum power priority.
		10-19 = Dynamic	Fan speed according to LED temperature. Maximum power priority.
		20-29 = Full Speed	Fan operates at maximum power.
		> =30 = Dynamic	Fan speed according to LED temperature. Maximum power priority.
27	Kelvin	0-255	2500K to 10000K
28	Saturation	0-255	0-100
29	Gel family	0=L 1=R	See document L GEL list See document R GEL list
30	Gel number	0-255	0-100
31	ZOOM	0-255	13°-56°
32	FAN	0-9 = Silence	Fan speed according to LED temperature. Maximum power priority.
		10-19 = Dynamic	Fan speed according to LED temperature. Maximum power priority.
		20-29 = Full Speed	Fan operates at maximum power.
		> =30 = Dynamic	Fan speed according to LED temperature. Maximum power priority.
33	Kelvin	0-255	2500K to 10000K
34	Saturation	0-255	0-100
35	Light Source number	0-255	See document Lightsources list
36	ZOOM	0-255	13°-56°
37	FAN	0-9 = Silence	Fan speed according to LED temperature. Maximum power priority.
		10-19 = Dynamic	Fan speed according to LED temperature. Maximum power priority.
		20-29 = Full Speed	Fan operates at maximum power.
		> =30 = Dynamic	Fan speed according to LED temperature. Maximum power priority.
38	Preset number	0-255	0-10
39	FAN	0-9 = Silence	Fan speed according to LED temperature. Maximum power priority.
		10-19 = Dynamic	Fan speed according to LED temperature. Maximum power priority.
		20-29 = Full Speed	Fan operates at maximum power.
		> =30 = Dynamic	Fan speed according to LED temperature. Maximum power priority.
40	DISCO Loop speed	0-255	0-100
41	DISCO Saturation	0-255	0-100
42	DISCO Hue 1	0-255	0° to 359°
43	DISCO Hue 2	0-255	0° to 359°

44	DISCO Kelvin	0-255	2500K to 10000K
45	DISCO Smoothness	0-255	0-100
46	DISCO Direction	0-255	0-100
47	Parameter #8	0-255	0-100
48	ZOOM START Position	0-255	13°-56°
49	ZOOM STOP Position	0-255	13°-56°
50	ZOOM SPEED	0-255	0-100
51	FAN	0-9 = Silence	Fan speed according to LED temperature. Maximum power priority.
		10-19 = Dynamic	Fan speed according to LED temperature. Maximum power priority.
		20-29 = Full Speed	Fan operates at maximum power.
		> =30 = Dynamic	Fan speed according to LED temperature. Maximum power priority.
52	FLAME Flickr speed	0-255	0-100
53	FLAME Saturation	0-255	0-100
54	FLAME Hue	0-255	0° to 359°
55	FLAME Kelvin	0-255	2500K to 10000K
56	FLAME Smoothness	0-255	0-100
57	Parameter #6	0-255	0-100
58	Parameter #7	0-255	0-100
59	Parameter #8	0-255	0-100
60	ZOOM START Position	0-255	13°-56°
61	ZOOM STOP Position	0-255	13°-56°
62	ZOOM SPEED	0-255	0-100
63	FAN	0-9 = Silence	Fan speed according to LED temperature. Maximum power priority.
		10-19 = Dynamic	Fan speed according to LED temperature. Maximum power priority.
		20-29 = Full Speed	Fan operates at maximum power.
		> =30 = Dynamic	Fan speed according to LED temperature. Maximum power priority.
64	POLICE Loop speed	0-255	0-100
65	POLICE Saturation	0-255	0-100
66	POLICE Hue 1	0-255	0° to 359°
67	POLICE Hue 2	0-255	0° to 359°
68	POLICE Kelvin	0-255	2500K to 10000K
69	POLICE Smoothness	0-255	0-100
70	Parameter #7	0-255	0-100
71	Parameter #8	0-255	0-100
72	ZOOM START Position	0-255	13°-56°
73	ZOOM STOP Position	0-255	13°-56°
74	ZOOM SPEED	0-255	0-100
75	FAN	0-9 = Silence	Fan speed according to LED temperature. Maximum power priority.
		10-19 = Dynamic	Fan speed according to LED temperature. Maximum power priority.
		20-29 = Full Speed	Fan operates at maximum power.
		> =30 = Dynamic	Fan speed according to LED temperature. Maximum power priority.
76	PULSE Loop speed	0-255	0-100
77	PULSE Flash time	0-255	0-100
78	PULSE Fade out	0-255	0-100

79	PULSE Saturation	0-255	0-100
80	PULSE Hue	0-255	0° to 359°
81	PULSE Kelvin	0-255	2500K to 10000K
82	Parameter #7	0-255	0-100
83	Parameter #8	0-255	0-100
84	ZOOM START Position	0-255	13°-56°
85	ZOOM STOP Position	0-255	13°-56°
86	ZOOM SPEED	0-255	0-100
87	FAN	0-9 = Silence	Fan speed according to LED temperature. Maximum power priority.
		10-19 = Dynamic	Fan speed according to LED temperature. Maximum power priority.
		20-29 = Full Speed	Fan operates at maximum power.
		> =30 = Dynamic	Fan speed according to LED temperature. Maximum power priority.
88	STROBE Saturation	0-255	0-100
89	STROBE Hue	0-255	0° to 359°
90	STROBE Kelvin	0-255	2500K to 10000K
91	STROBE Flash time	0-255	0-100
92	Parameter #5	0-255	0-100
93	Parameter #6	0-255	0-100
94	Parameter #7	0-255	0-100
95	Parameter #8	0-255	0-100
96	ZOOM START Position	0-255	13°-56°
97	ZOOM STOP Position	0-255	13°-56°
98	ZOOM SPEED	0-255	0-100
99	FAN	0-9 = Silence	Fan speed according to LED temperature. Maximum power priority.
		10-19 = Dynamic	Fan speed according to LED temperature. Maximum power priority.
		20-29 = Full Speed	Fan operates at maximum power.
		> =30 = Dynamic	Fan speed according to LED temperature. Maximum power priority.
100	TV Loop speed	0-255	0-100
101	TV Saturation	0-255	0-100
102	TV Hue 1	0-255	0° to 359°
103	TV Hue 2	0-255	0° to 359°
104	TV Smoothness	0-255	0-100
105	TV Direction	0-255	0-100
106	Parameter #7	0-255	0-100
107	Parameter #8	0-255	0-100
108	ZOOM START Position	0-255	13°-56°
109	ZOOM STOP Position	0-255	13°-56°
110	ZOOM SPEED	0-255	0-100
111	FAN	0-9 = Silence	Fan speed according to LED temperature. Maximum power priority.
		10-19 = Dynamic	Fan speed according to LED temperature. Maximum power priority.
		20-29 = Full Speed	Fan operates at maximum power.
		> =30 = Dynamic	Fan speed according to LED temperature. Maximum power priority.
112	PAPARAZZI Kelvin	0-255	2500K to 10000K
113	PAPARAZZI Flicker speed	0-255	0-100

114	PAPARAZZI Flash time	0-255	0-100
115	Parameter #4	0-255	0-100
116	Parameter #5	0-255	0-100
117	Parameter #6	0-255	0-100
118	Parameter #7	0-255	0-100
119	Parameter #8	0-255	0-100
120	ZOOM START Position	0-255	13°-56°
121	ZOOM STOP Position	0-255	13°-56°
122	ZOOM SPEED	0-255	0-100
123	FAN	0-9 = Silence	Fan speed according to LED temperature. Maximum power priority.
		10-19 = Dynamic	Fan speed according to LED temperature. Maximum power priority.
		20-29 = Full Speed	Fan operates at maximum power.
		> =30 = Dynamic	Fan speed according to LED temperature. Maximum power priority.
124	SUNRISE Intensity 1	0-255	0-100
125	SUNRISE Intensity 2	0-255	0-100
126	SUNRISE Saturation 1	0-255	0-100
127	SUNRISE Saturation 2	0-255	0-100
128	SUNRISE Hue 1	0-255	0° to 359°
129	SUNRISE Hue 2	0-255	0° to 359°
130	SUNRISE Kelvin	0-255	2500K to 10000K
131	SUNRISE Time	0-255	0-100
132	ZOOM START Position	0-255	13°-56°
133	ZOOM STOP Position	0-255	13°-56°
134	ZOOM SPEED	0-255	0-100
135	FAN	0-9 = Silence	Fan speed according to LED temperature. Maximum power priority.
		10-19 = Dynamic	Fan speed according to LED temperature. Maximum power priority.
		20-29 = Full Speed	Fan operates at maximum power.
		> =30 = Dynamic	Fan speed according to LED temperature. Maximum power priority.
136	TRANSITION Light intensity 1	0-255	0-100
137	TRANSITION Light intensity 2	0-255	0-100
138	TRANSITION Hue 1	0-255	0° to 359°
139	TRANSITION Hue 2	0-255	0° to 359°
140	TRANSITION Time	0-255	0-100
141	Parameter #6	0-255	0-100
142	Parameter #7	0-255	0-100
143	Parameter #8	0-255	0-100
144	ZOOM START Position	0-255	13°-56°
145	ZOOM STOP Position	0-255	13°-56°
146	ZOOM SPEED	0-255	0-100
147	FAN	0-9 = Silence	Fan speed according to LED temperature. Maximum power priority.
		10-19 = Dynamic	Fan speed according to LED temperature. Maximum power priority.
		20-29 = Full Speed	Fan operates at maximum power.
		> =30 = Dynamic	Fan speed according to LED temperature. Maximum power priority.

KELVIN DMX (Firmware V01_05)

DMX	KELVIN
0	2500
3	2600
6	2700
9	2800
12	2900
15	2900
18	3000
21	3100
24	3200
27	3300
30	3400
33	3500
36	3600
39	3600
42	3700
45	3800
48	3900
51	4000
54	4100
57	4200
60	4300
63	4400
66	4400
69	4500
72	4600
75	4700
78	4800
81	4900
84	5000
87	5100
90	5100
93	5200
96	5300
99	5400
102	5500
105	5600
108	5700
111	5800
114	5900
117	5900
120	6000
123	6100
126	6200

129	6300
132	6400
135	6500
138	6600
141	6600
144	6700
147	6800
150	6900
153	7000
156	7100
159	7200
162	7300
165	7400
168	7400
171	7500
174	7600
177	7700
180	7800
183	7900
186	8000
189	8100
192	8100
195	8200
198	8300
201	8400
204	8500
207	8600
210	8700
213	8800
216	8900
219	8900
222	9000
225	9100
228	9200
231	9300
234	9400
237	9500
240	9600
243	9600
246	9700
249	9800
252	9900
255	9900

DIMMING CURVE

The dimming curve is the correlation between the change in the value of the dimming control and the actual change in the fixture's light intensity. Curve is also the extent to which the fixture delays its response time to the control signal in order to smooth dimmin

To set the Dimming Curve of the fixture push  and then push the *CURVE* button.

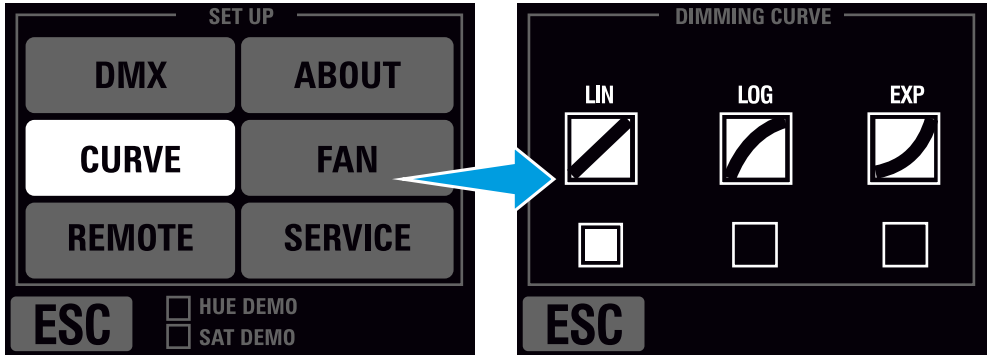

Linear (Default)

Brightness levels correlate exactly with the value of the dimming control
Moderate lag in response for good dimming smoothness.
Linear allows quick jumps in brightness.

Logarithmic

The resolution is low at lower intensity levels and high at higher intensity levels.
Use this attenuation curve when you need fast rises from 0 to 100.

Exponential

The resolution is high at lower intensity levels and low at higher intensity levels.
Use this dimming curve when you need a high resolution at low intensity levels.

Fixture control

- Ethernet Art-Net (exclusively on KOSMOS Studio)
- KOSMOS Location has wireless control of Art-Net via Wi-Fi
- KOSMOS Studio has two Art-Net* control options:
 - Wire control through Ethernet RJ-45 connect
 - Wireless control through Wi-

*Art-Net™ Designed by and Copyright Artistic Licence Holdings Ltd is a network protocol to control devices. For more detailed information, please visit the site of the Art-Net developers www.artisticlicence.com

ETHERNET

Push  and push *REMOTE* button. and select *ETHERNET*.

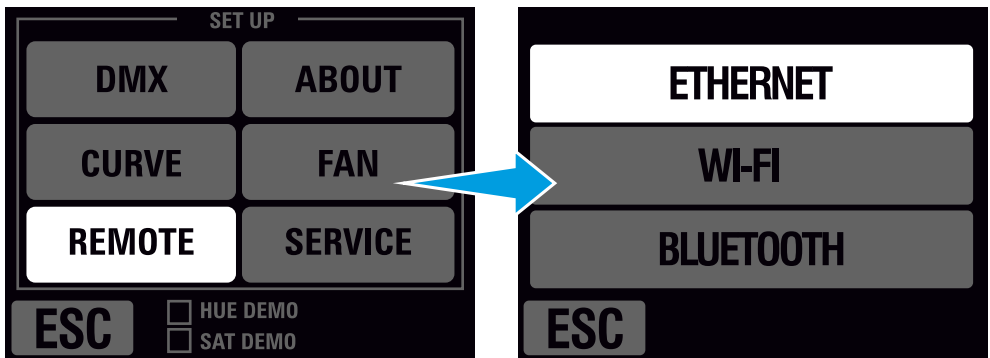

Ethernet function shows the following information:

IP Mode	DHCP / 2.x.x.x / 10.x.x.x
Connection status	Connected / Unconnected
IP	When KOSMOS is connected to a network it shows the fixture IP address.
MAC	When KOSMOS is connected to a network it shows the fixture MAC address.

To set the IP Mode push the *IP MODE* button to select the mode and then push *APPLY*

IP Modes

DHCP	The IP address is automatically assigned to the fixture by the network
2.x.x.x	Mode to set up the fixture in an Art-Net netwo
10.x.x.x	Mode to set up the fixture in an Art-Net netwo

NOTE

As soon as a wired signal is detected via the other interface (DMX-512A through XLR-5 connector), any wire Art-Net data will be ignored and the KOSMOS will only process the DMX-512A wired command

WIRELESS CONTROL

KOSMOS CPU's includes a highly advanced hardware with a dedicated software to offer the user full wireless control..

KOSMOS Location

- DMX-RDM through LumenRadio CRMX
- Wi-Fi Art-Net to control from smartphone or tablet with VELVET GOYA* App (or any third party device or App).
- Bluetooth control from smartphone or tablet with VELVET GOYA* App (or any third party device or App).

KOSMOS Studio

- Wi-Fi Art-Net to control from smartphone or tablet with VELVET GOYA* App (or any third party device or App).
- Bluetooth control from smartphone or tablet with VELVET GOYA* App (or any third party device or App).



*Using a Smartphone or tablet with VELVET Goya App you get full, intuitive contro

VELVET Goya App is available free of charge for Android and iOS

WI-FI ART-NET

Every KOSMOS fixture is equipped with a Wi-Fi Art-Net* system to wirelessly control the fixture

*Art-Net™ Designed by and Copyright Artistic Licence Holdings Ltd is a network protocol to control devices. For more detailed information, please visit the site of the Art-Net developers www.artisticlicence.com

PARA ENLAZAR EL KOSMOS CON CUALQUIER DISPOSITIVO WI-FI

Smartphone, tablet or computer it is mandatory to use a VELVET Router (ref. VE-ROUTER) or alternatively any Wi-Fi router in which you need to change the SSID and password to make it compatible with KOSMOS.



If you want to use your own router you need to configure it with these credentials:

SSID: **VELVET Router**
 Password: **velvetrouter**

NOTA

The KOSMOS can be linked to any Wi-Fi device through the Wi-Fi Router if there is no DMX signal received via a wired interface (DMX-512A through XLR-5 connector or Art-Net through Ethernet connector) or via wireless DMX LumenRadio and Wi-Fi is activated via the fixture menu

When the device is controlled remotely via Art-Net (wired or wireless), it is automatically and exclusively set to the DMX mode called CHANGE. Which means that you must patch your console or control software with the CHANGE mode according to the DMX Map you will find on page 59 of this manual.

TO ACTIVATE WI-FI

Push  and push the *REMOTE* button. Select *WI-FI*. The fixture will now automatically connect to any available VELVET Router

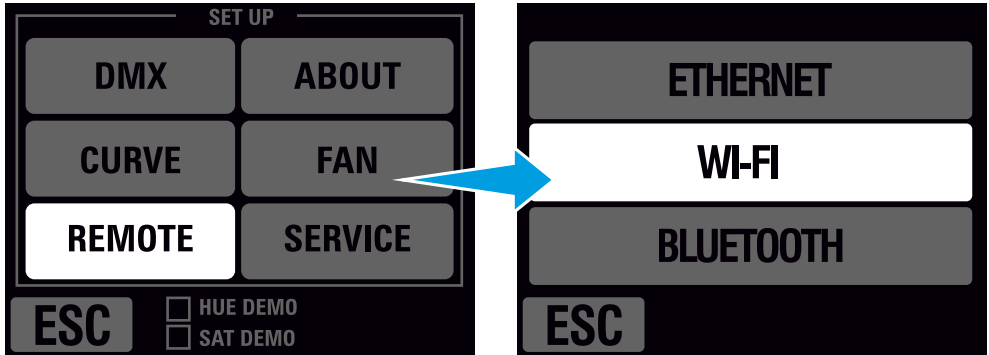

Once "WI-FI" is activated, the color display will show the following information:

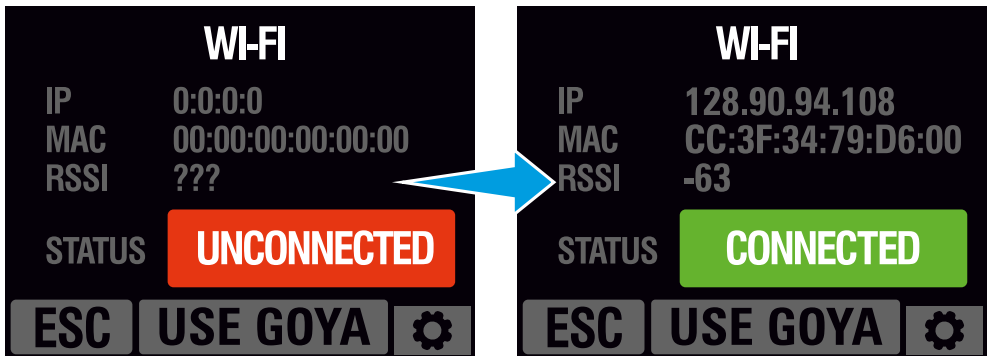

CONTROL WI-FI VÍA VELVET GOYA APP

Push the button *USE GOYA* to activate the function so that the button turns into green.

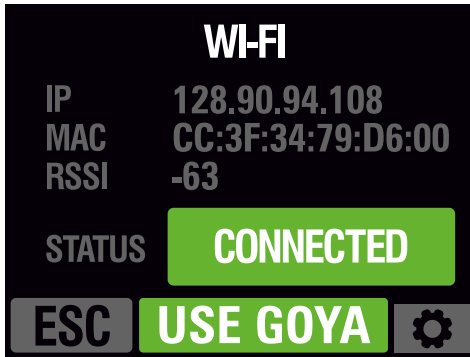

If you do not press *USE GOYA*, you will be able to have Wi-Fi control but not with the profile that VELVET Goya uses, i.e., the commands will respond but not with the proper parameters.

WI-FI CONTROL VIA THIRD PARTY APPS

1. Deactivate the *USE GOYA* function (the button turns gray) and press the button  and then *DMX*.
2. Select *DMX ADDRESS* to enter the *DMX* address.
3. Then select the Mode you want to work with.
4. Finally, press ESC twice to return to WI-Fi mode.

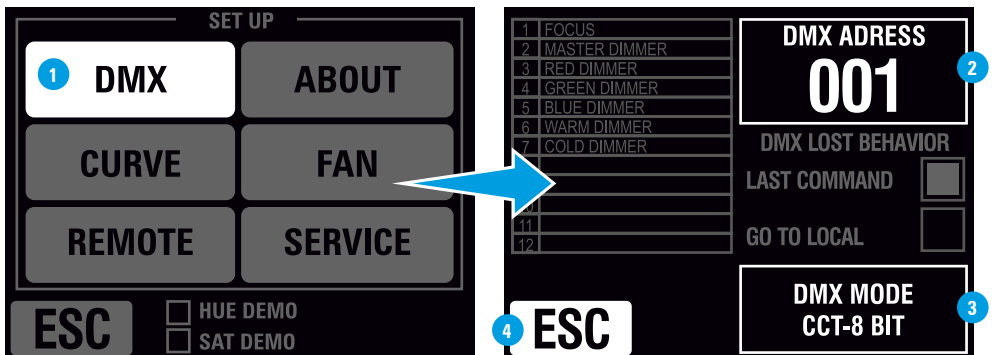

TO DISACTIVATE WI-FI

Push *ESC* to exit from the Wi-Fi screen and the KOSMOS will no longer react to Wi-Fi command.

NOTA

As soon as a wired signal is detected via the other interfaces (DMX-512A through XLR-5 connector or Art-Net through RJ45 Ethernet connector) any Wi-Fi data will be ignored and the KOSMOS only processes the wired DMX/RDM signal or the Ethernet.

BLUETOOTH

Every KOSMOS is equipped with a Bluetooth system to wirelessly control the fixture.

The KOSMOS can be linked to any Bluetooth device if there is no DMX signal received via a wired interface (DMX-512A through XLR-5 connector or Art-Net through Ethernet connector) and Bluetooth is activated via the fixture menu.

TO ACTIVATE BLUETOOTH

Push  and push the REMOTE button. Select "BLUETOOTH". The fixture can now be detected by any Bluetooth device.

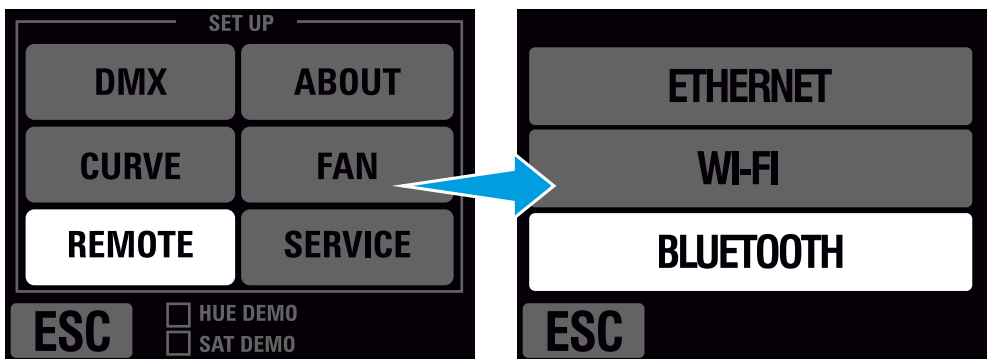

BLUETOOTH CONTROL VIA VELVET GOYA APP

Push the button *USE GOYA* to activate the function so that the button turns into green.

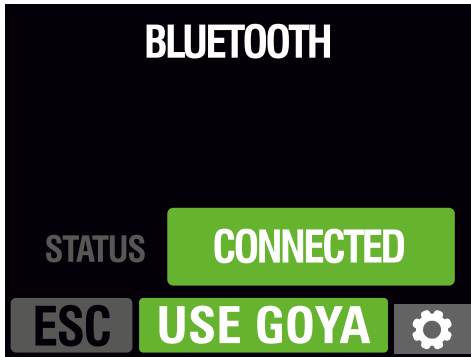

BLUETOOTH CONTROL VIA THIRD PARTY APPS

1. Deactivate the *USE GOYA* function (the button turns gray) and press the  button and then *DMX*.
2. Select *DMX ADDRESS* to enter the DMX address.
3. Then select the Mode you want to work with.
4. Finally, press *ESC* twice to return to Wi-Fi mode.

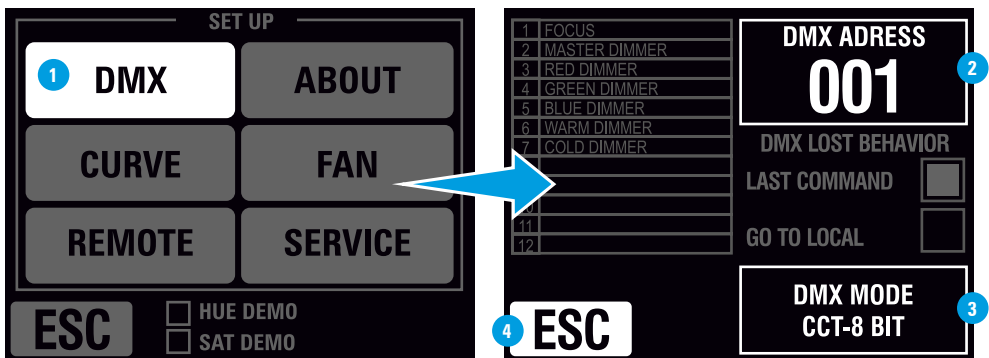

TO DISACTIVATE BLUETOOTH

Push *ESC* to exit from the BLUETOOTH screen and the KOSMOS will no longer react to Wi-Ficommand

NOTA

As soon as a wired DMX signal is detected via the other interfaces (DMX-512A via the XLR5 connector or wired Art-Net via the Ethernet RJ-45 connector), any wireless Art-Net data will be ignored and the KOSMOS will only process the wired signal.

VELVET GOYA APP

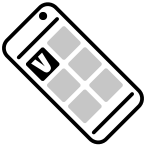

Lets you remotely control any KOSMOS as well as any EVO from any smartphone or tablet (Android or iOS) through two compatible ways.

Ways of control

- Wi-Fi to control unlimited number of fixtures up to 100 meters/ 330 feet distance through a VELVET Router (sold separately).
- BLUETOOTH to individually control up to 4 fixtures from up to 30 meters / 100 feet distance.

The App automatically discovers any available KOSMOS or EVO fixture and offers full control with its attractive and intuitive interface.

Control options

VELVET Goya offers 2 control options:

- SINGLE CONTROL is a quick and easy interface to control single KOSMOS or EVO fixtures, create and save your own white light, color setting or gels.
- PROJECTS is an advanced control to create off-line or on-line lighting projects and scenes using unlimited number of KOSMOS and EVO fixtures.

Control Modes

You can easily adjust, create and save your white or color light in several intuitive modes:

- CCT, with Intensity / Kelvin 2500K-10000K / and Green-Magenta channel.
- HSI, with Hue / Saturation / Intensity wheel on any white base from 2500 to 10000K.
- RGB, with each channel separately for RED / GREEN / BLUE / WHITE / COLD WHITE / Master Intensity
- GELS with a wide catalog of Gelatines / Light Sources and Presets to save your own Gels created from any of the modes.

The ZOOM (beam angle control) can be adjusted at any moment combined with any control mode.

Using PROJECTS you can work both on-line or off-line to easily create your light designs and scenes. You can group light fixtures, display and move them over your set, rename them or add new lights.

You will immediately identify the KOSMOS and EVO models by their shape while their actual color will always be visible.

In addition, at the bottom left of the VELVET Goya interface, the name and serial number of the luminaire is displayed and you can edit this identification to facilitate its location.

Conect KOSMOS with Goya via WI-Fi



Link the KOSMOS with any Wi-Fi device like smartphone, tablet or computer it is mandatory to use a VELVET automatic Router (ref. VE-ROUTER) or alternatively any Wi-Fi router in which you need to change the SSID and password to make them compatible with KOSMOS.

- Place the VELVET Router on a stable surface, clear of obstructions. It is recommended to place the device elevated above nearby objects and people to minimize physical interference.
 - Power on the VELVET Router through the 12V DC power supply. A blue indicator will light on.
 - Wait around 30 seconds until the blue Wi-fi indicator get solid.
 - Power on KOSMOS and activate its Wi-Fi function.
 - Power on your smartphone or tablet.
 - Select the Wi-Fi network named "VELVET Router".
 - Enter the PASSWORD "velvetrouter". If your smartphone or tablet shows a message warning you have not internet access then select "No internet".
 - Open the VELVET Goya app on the device you are going to work from, select SINGLE CONTROL or PROJECTS, depending on your needs and press the Wi-Fi icon to discover the available KOSMOS and/or EVO devices.
-

**Conect
KOSMOS
with Goya
via BLUETOOTH**



- Turn on the KOSMOS and activate *BLUETOOTH* by doing the following path: Settings/Remote/Bluetooth.
- Turn on the device you are going to work from.
- Enable Bluetooth on your smartphone or tablet
- Open VELVET Goya app on your device, select *SINGLE CONTROL* or *PROJECTS* in Goya and press the BLUETOOTH icon to discover available KOSMOS and/or EVO accessories.

NOTE

To avoid interference you should disconnect any other smartphone or tablet from the VELVET Router while using VELVET Goya.

ABOUT

Shows fixture model, fixture serial number, firmware version, RDM ID, Ethernet ID MAC, fixture temperature and LED running hours.

DEVICE INFO	
FIRMWARE REV	3.3.8.5-B
SERIALNUMBER	918308373473
RDM UID	07FD-F00A0BED
MAC	00:00:00:00:00:00
LED TEMP. LEVEL	3
LED 10W HOURS	7
OPERATING HOURS	12

ESC
DISPLAY TIMEOUT
OTA

FIRMWARE UPDATE

On the touchscreen push  and select *ABOUT*. On the sub-menu select *UPGRADE*.

To update the System Firmware push SYSTEM and follow the instructions written on the screen.

Copy the KOSMOS update file to the root of an USB memory stick.

1. Connect the USB memory stick to the USB connector of the KOSMOS back panel.
2. Push the top knob and keep it pressed.
3. Power on the KOSMOS. The KOSMOS will automatically start the update proces.
4. Now you can release the top knob. Once the firmware update process is finished the KOSMOS will reboot with the new firmware.and remove your USB memory stick.

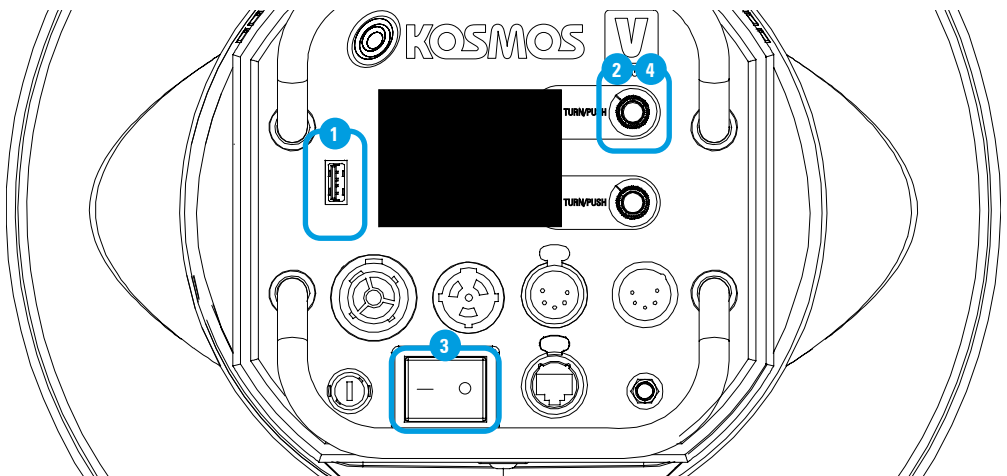

MAINTENANCE AND CARE

A visual inspection should be conducted before every use, and an inspection of electrical safety should be conducted at least once every 12 months.

Do not clean the fixture with solvents or strong detergents.

Clean the product with a soft cloth wetted with a mild detergent. Do not rub the surface: lift stuck particles off with a soft repeated press.

KOSMOS fixture require very little routine maintenance, if any. The cooling fan and electronics are protected by a special filter to refrain dust to enter into the fixture.

HOW TO CLEAN THE FAN FILTER

Unplug the device from power and let it cool down for a few minutes, if it has been on.

Remove the locking screw of the protection grille and then the fan filter from the bottom of the equipment.

Clean the filter using a vaccum cleaner.

Follow the reverse process to reassemble the filter, its protection grid and the locking screw.

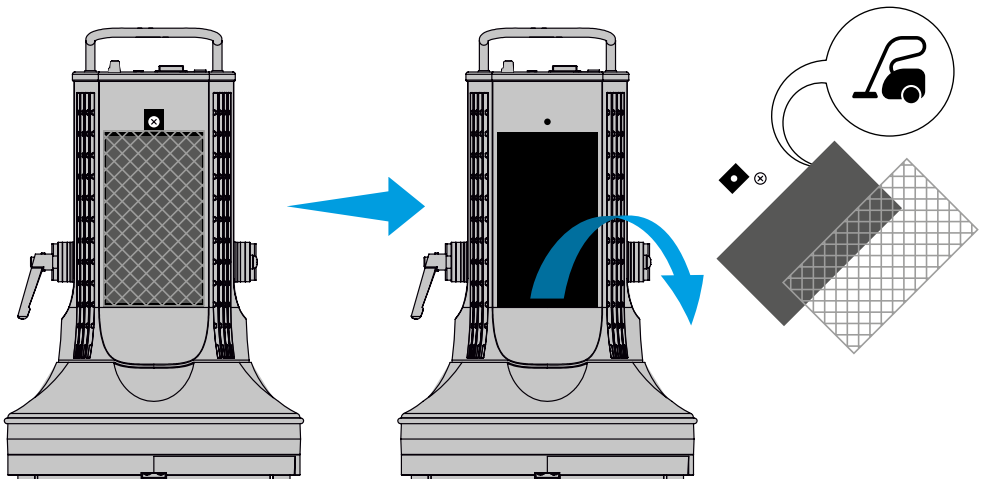

HOW TO CLEAN THE INSIDE OF KOSMOS

Clean the glass Fresnel lens with a soft, damp cloth.

Carefully clean the LED light engine lens and reflector with isopropyl alcohol and a cotton swab.

Clean the electrical contacts with cotton swabs dipped in isopropyl alcohol.

Keep the electrical contacts clean and replace oxidized parts.

Regulations

This equipment is designed to meet the following regulations and safety standards for battery powered technology equipment:

Environmental

Devices are certified and intended for indoor or outdoor use.

LAMP HEAD OPERATION TEMPERATURE from -20° to $+40^{\circ}$ C

OPERATING HUMIDITY from 30 to 90% RH non condensing

DECLARATION OF CONFORMITY TO EMC DIRECTIVE 2004/108 EC

Manufacturer Name & adress

VELVET (THELIGHT luminary for cine and tv, S.L.)

Carrer de la Cerdanya 11-A.

08192 Sant Quirze del Vallés. BARCELONA, SPAIN.

info@velvetlight.tv / www.velvetlight.tv

Standards

EC - DECLARATION OF CONFORMITY

Brand Name: VELVET

Product Description: LED Luminaire systems for professional use

VELVET Kosmos

VELVET Evo1, Evo2, Evo 2x2

VELVET Cyc3, Cyc4, Cyc5, Cyc6

VELVET Mini 1, Mini 2, Mini 3

VELVET Mini Power 1, Mini Power 2

VELVET Light 1, Light 2, Start 2, Light 2x2, Light 4

VELVET Power 1, Power 2, Power 2x2

VELVET Sword 2, Sword 4.

The above products abide by the following European Directives:

DIRECTIVE 2014/30/EU of the European Parliament and of the Council of 26 February 2014 on the harmonization of the laws of the Member States relating to electromagnetic compatibility.

DIRECTIVE 2014/35/EU of the European Parliament and of the Council of 26 February 2014 on the harmonization of the laws of the Member States relating to the making available on the market of electrical equipment designed for use within certain voltage limits.

DIRECTIVE 2001/95/EC of the European Parliament and the Council of 3 December 2001 on general product safety.

DIRECTIVE 2011/65/EU of the European Parliament and of the Council of 8 June 2011 on the restriction of the use of certain hazardous substances in electrical and electronic equipment.

In compliance with the harmonized standards:

IEC 60598-1:2014 Luminaires - Part 1: General requirements and tests.

IEC 60598-1-17:2017 Luminaires - Part 2-17: Particular requirements - Luminaires for stage lighting, television and film studios (outdoor and indoor).

IEC 62031:2008/A1:2012 LED modules for general lighting - Safety specifications.

IEC 61547:2009 Equipment for general lighting purposes - EMC immunity requirements.

IEC 61000-6-1:2005 Electromagnetic compatibility (EMC) - Part 6-1: Generic standards - Immunity for residential, commercial and light-industrial environments.

IEC 61000-6-3:2006/A1:2010 Electromagnetic compatibility (EMC) - Part 6-3: Generic standards - Emission standard for residential, commercial and light-industrial environments.

IEC 61000-6-4:2006/A1:2010 Electromagnetic compatibility (EMC) - Part 6-4: Generic standards - Emission standard for industrial environments.

EN 301489-1 V1.8.1 Electromagnetic compatibility and Radio spectrum Matters (ERM); Electromagnetic Compatibility (EMC) standard for radio equipment and services; Part 1: Common technical requirements.

IEC 62493:2009 Assessment of lighting equipment related to human exposure to electromagnetic fields.

EN 55015:2013 Limits and methods of measurement of radio disturbance characteristics of electrical lighting and similar equipment.

RED 2014/53/EU Radio equipment directive.

EN 62471:2008 Photobiological Safety of Lamps and Lamp Systems.

Sant Quirze del Vallés. BARCELONA, 1 June 2021
Administrator - Javier Fdez. de Valderrama



Warranty

General warranty

VELVET LED light equipments are guaranteed to be free from defects in workmanship and parts in a warranty period of two (2) years from the date of purchase. Defects that occur within this warranty period, under normal use and care will be repaired or replaced at VELVET discretion, solely at our option with no charge for parts or labour.

In the event of the equipment malfunction, contact the dealer from which you purchased the product. Please note that you will be not be reimbursed for the cost of bringing the equipment to the VELVET Repair Centre.

VELVET reserves the right to replace the product or relevant part with the same or equivalent product or part, rather than repair it. Where a replacement is provided the products or part replaced becomes the property of VELVET. VELVET may replace parts with refurbished parts. Replacement of the product or a part does not extend or restart the Warranty period.

Return policy

Returns or exchanges from the customers will be accepted within 15 days of delivery and will not include the actual shipping costs. Item(s) must be in original packaging and condition, must not be assembled, and must include its original user manual.

This warranty does not cover any damage resulting from:

- Failure to follow the instructions in the instruction manual Repair, modification or overhaul not conducted by any authorized VELVET personnel.
- Fire, natural disaster, act of God, lightning, abnormal voltage, etc;
- Submergence in water (flooding), exposure to alcohol or other beverages, infiltration of sand or mud, physical shock, or dropping of the equipment and other unnatural causes.

This warranty only applies to the LED panel and not to the accessories, such as barn doors or mounts.

Any consequential damages arising from failure of the equipment, such as expenses incurred in taking pictures or recording images or loss of expected profit, will not be reimbursed whether they occur during the warranty period or not.

Parts essential to the servicing of the light equipment (that is, components required to maintain the functions and quality of the fixture) will be available for a period of five years after the product is discontinued.

THELIGHT Luminary for cine and tv, S.L.

www.velvetlight.tv

The total or partial reproduction of this guide is prohibited without the express written permission of VELVET.

VELVET technology is protected under Spanish license laws with international patents pending.

Information and specifications in this document are subject to change without notice.

2022 © Copyright VELVET. All rights reserved

QR Links

[KOSMOS website link](#)



[KOSMOS suport documents link](#)

- Última versión del Manual de usuario
- Descarga el último firmware
- Configuración del Router
- Folleto
- Última versión del mapa DMX







**Design, Engineering
& Production center**

Carrer de la Cerdanya. 11A
08192 — St. Quirze del Vallès
Barcelona (Spain)
+34 937 073 011
info@velvetlight.tv

VELVET USA Office

7411 Laurel Canyon, unit 3
North Hollywood, CA 91605
+1 (818) 358 2888
usa@velvetlight.tv
